



www.pumps.com.tw

BAH series

High Head 2 Stages Submersible pump Non-Clogging Vortex Impeller

Liquid temperature : 0 °C to 40 °C / +32 °F to +104 °F

HP range : 1/2 to 1HP / 400 W to 750 W

pH : 6 to 8

Protection class : IP68

Maximum immersion depth : 6M

Solid pass : 8mm



Civil engineering & construction.



Agriculture and irrigation at high mountain slope.



Wastewater system



Discharge water

HUNG PUMP GROUP

High Pressure Pumps

Dimension					
Model	A	B	C	D	E
	mm	mm	mm	mm	mm
BAH-400	369	141	227	220	151
BAH-750	474	165	245	233	170

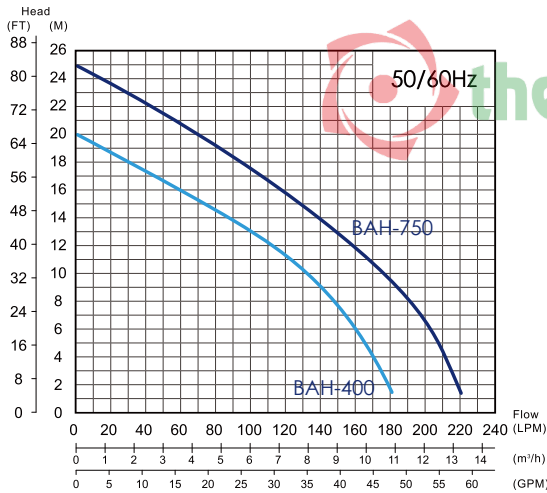
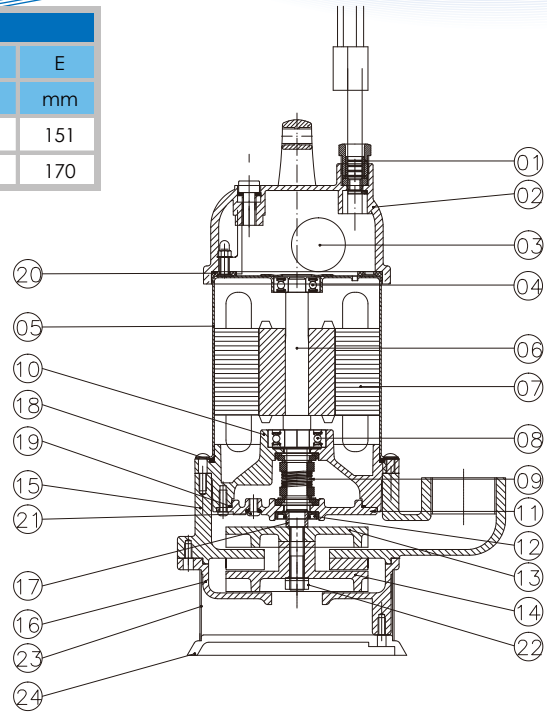
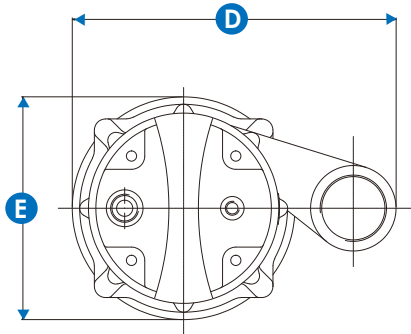
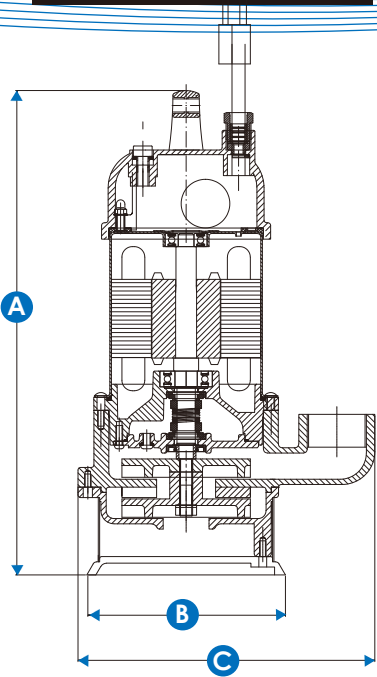

Construction					
No.	Description	Material	No.	Description	Material
1	Power Cord		13	Upper Impeller	FC200
2	Top Cover	PA+GF	14	Lower Impeller	FC200
3	Capacitor		15	Upper Pump Casing	FC200
4	Upper Bearing		16	Lower Pump Casing	FC200
5	Motor Housing	SUS304	17	Sleeve	SUS304
6	Shaft / Rotor	SUS410	18	O-ring	NBR
7	Stator / Coil	C60	19	O-ring	NBR
8	Lower Bearing		20	Packing	NBR
9	Double Mech. Seal	CA/CE	21	Screw	SUS304
10	Seal Plate	FC200	22	Nut	SUS304
11	Oil Seal Cover	FC200	23	Strainer	SUS304
12	Oil Seal	NBR	24	Base	FC200

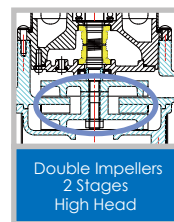

Specification														
Model	Output		Outlet		Solid Pass Dia (mm)	Max Flow (LPM)	LPM Flow @ Head					Max Head (M)	Dimension L x W x H (mm)	Weight (Kg)
	HP	W	mm	inch			3M	6M	9M	12M	15M			
BAH-400	1/2	400	32	1-1/4"	8	180	175	160	140	115	75	20	227 x 141 x 369	16
BAH-750	1	750	40	1-1/2"		220	215	200	185	160	130	25	245 x 165 x 474	17