



BPS-100/200/300/ 400 Utility Submersible Pumps

FEATURES:

- Non-corrosive super-touch glass fiberreinforcing the thermoplastic motor housing, pump casing and impeller.
- Build - in thermal overload protector.
- Light-weighted and compacted easy for hand carry.
- Light weight and compacted design for protable residential usages.
- BPS-100 can pump at the lowest residual water level 3mm.

■ BPS-100A

■ BPS-100V



■ BPS-300
BPS-400



■ BPS-200



■ BPS-100



APPLICATIONS:

- Sump-pit, garden spraying, fountain, waterfall, toilet, aundry, car wash, irrigation and various portable usages.



Performance

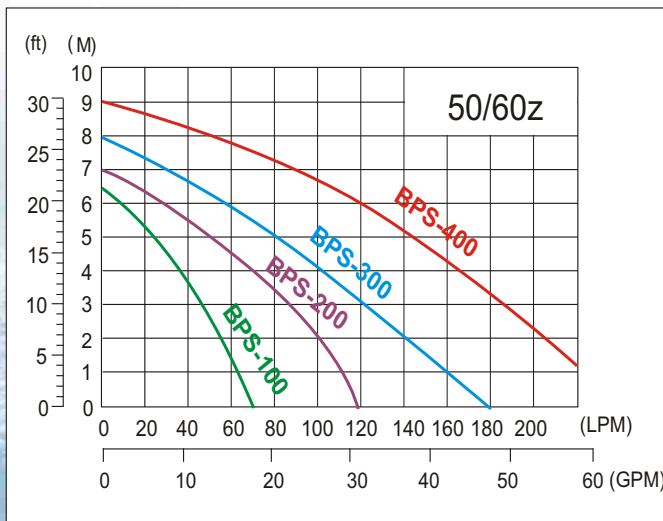

BPS-100

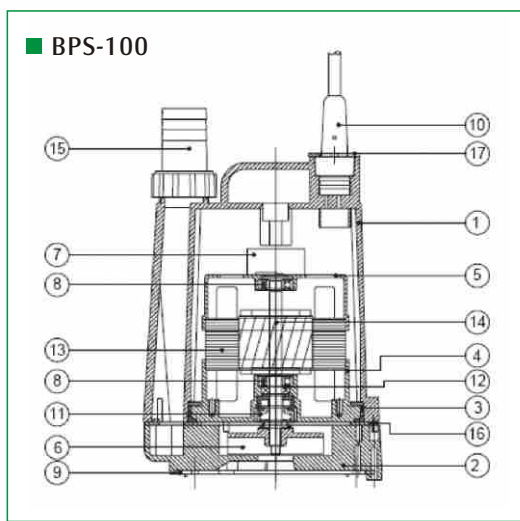

Construction

BPS-300/ 400

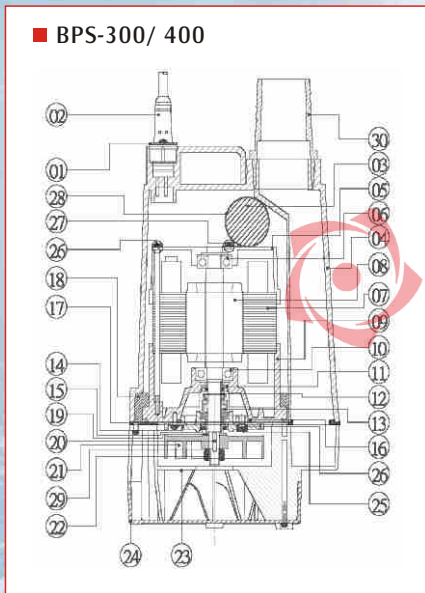

BPS-200

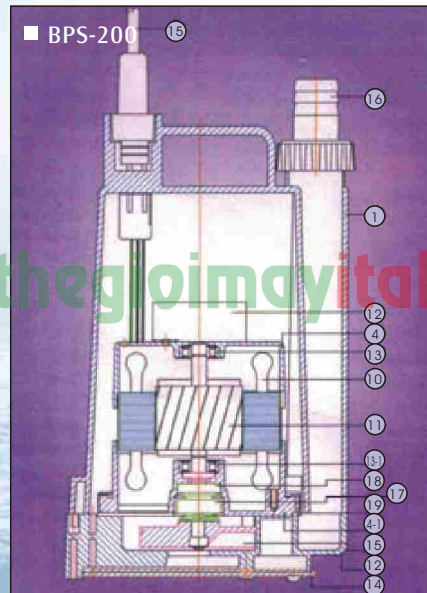

BPS-300/ 400

NO	Description	Material
1	Gland Plate	SUS
2	Power Cord	H05RNF/H07RNF
3	Capacitor	15UF/350V
4	Motor Tank	PP+GF
5	Upper Bearing Cover	ADC12
6	Bearing	NTN
7	Stator	Laminated S.S. P
8	Shaft	SUS410
9	Seal Plate	ADC12
10	Bearing	NTN
11	Oil Seal	NBR
12	C Retain Ring	SUS
13	Me. Seal	CA/CE
14	Oil Seal Cover	FC-20
15	Oil Seal	NBR
16	O-Ring	NBR
17	Pump Casing Gasket	NBR
18	Gasket	NBR
19	Bearing	NTN
20	KEY	SUS
21	Impeller	Nylon+GF
22	Nut	SUS
23	Pump Casing	PP+GF
24	Strainer	PP+GF
25	Oil Seal Screw	SUS
26	Oil Seal Packing	NBR
27	Screw	SUS
28	Capacitor Retaining Ring	Steel, Plated
29	Spring Washer	SUS
30	Discharge Fitting	PP+GF

BPS-100

NO	Description	Material
1	Motor Housing	PP+GF
2	Pump Casing	PP+GF
3	Pump Gasket	NBR
4	Lower Bearing	ADC12
5	Upper Bearing	ADC12
6	Impeller	PP+GF
7	Capacitor	
8	Bearing	NTN
9	Strainer	NYLON
10	Power Cord	18AWG
11	Mechanical Seal	CA/CE
12	Oil Seal	NBR
13	Laminated Plate	Silicon Steel
14	Shaft	SUS
15	Discharge	PP
16	O-Ring	NBR
17	C Gland	SUS

BPS-200

NO	Description	Material
1	Motor Housing	PP+GF
2	Pump Casing	PP+GF
4	Stator Upper Casing	Aluminium
4-1	Stator Lower Casing	Aluminium
5	Impeller	PP+GF
10	Stator	
11	Rotor & Shaft	SUS304
12	Capacitor	
13	Bearing(Lower)	CNM5K
13-1	Bearing(Upper)	CNM5K
14	Strainer	NYLON
15	Cable With Plug	
16	Discharge Adapter	NYLON
17	Mechanical Seal	CE/CA
18	Oil Seal	NBR
19	Packing	NBR



Hung Pump Group

16 Lien-Ming Street, Ba-De City 334 ,
 Taoyuan, Taiwan
 TEL:(886) -3-371-3969
 FAX:(886) -3-371-3996
 E-Mail: hungpump@ms9.hinet.net

Specifications

Model	Output		Outlet		Rated		Maximum		Dimension	Weight
	HP	W	mm	Inch	Head(M)	Flow(l/m)	Head(M)	Flow(l/m)	L x W x H (mm)	
BPS-100	1/6	100	25	1"	4	35	6.5	70	155*155*240	2.9
BPS-200	1/4	200	32	1-1/4"	5	60	7	110	155*155*240	2.9
BPS-300	1/3	300	40	1-1/2"	5	80	8	180	196*196*365	6.6
BPS-400	1/2	400	50	2"	6	120	9	240	196*196*365	7.6

Remarks: Model No. ends with "A" construction with wide angle float switch, ex: BPS-100A.
 Model No. ends with "V" construction with vertical switch, ex: BPS-100V.