



www.pumps.com.tw

JK series

Non-Clogging Submersible Sewage Pumps

Liquid temperature : 0 °C to 40 °C / +32 °F to +104 °F

HP range : 1/2 to 7.5 HP / 0.4 kW to 5.5kW

pH : 6 to 8

Protection class : IP68

Maximum immersion depth : 8M

Solid pass : 30~50mm



 thegiocmayitaly.vn



For liquids with a high solid content or with filamentous particles



Civil Engineering & Construction

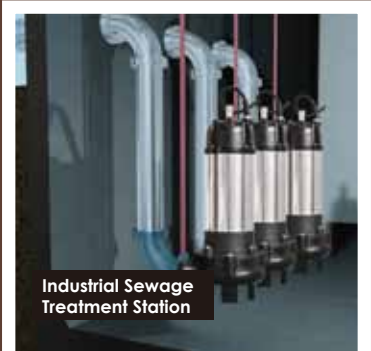

Industrial Sewage Treatment Station

HUNG PUMP GROUP

Sewage Pumps

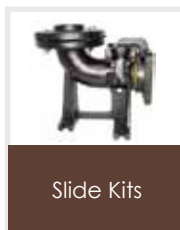
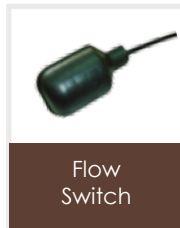
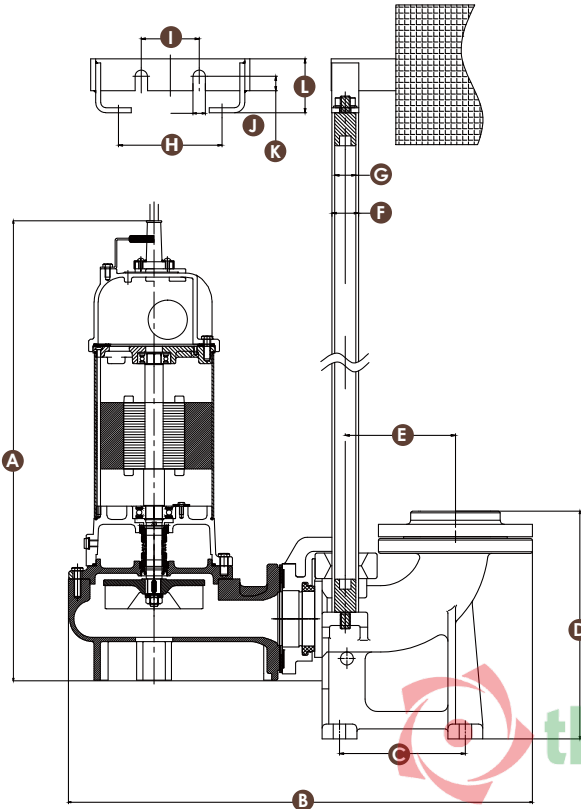
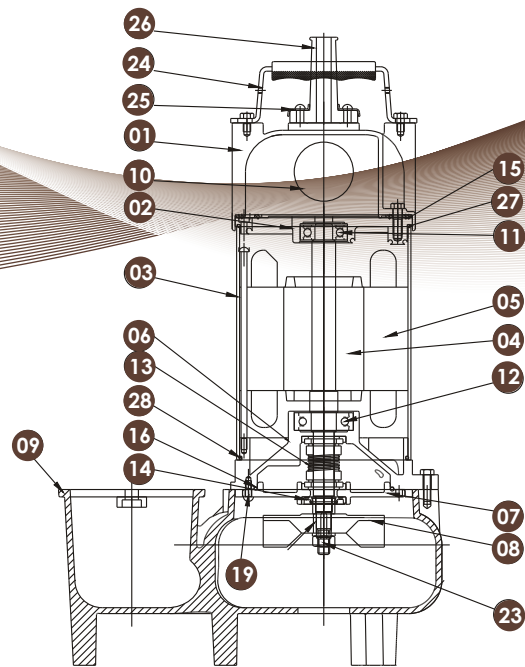

Construction					
No.	Description	Material	No.	Description	Material
1	Top Cover	FC200	12	Ball Bearing	
2	Upper Bearing Cover	FC200	13	Mechanical Seal	CA/CE
3	Motor Housing	SUS304	14	Oil Seal	NBR
4	Shaft	SUS410	15	Upper Gasket	NBR
5	Stator	Silicon	16	O-Ring	NBR
6	Seal Plate	FC200	23	Nut	SUS304
7	Mechanical Seal Cover	FC200	24	Handle Cover	SUS+Rubber
8	Impeller	FC200	25	Gland Cover	SUS304
9	Pump Casing	FC200	26	Cable Gland	NBR
10	Capacitor		27	O-Ring	NBR
11	Ball Bearing		28	O-Ring	NBR

Dimension												
Model	A	B	C	D	E	F	G	H	I	J	K	L
	mm	mm	mm	mm	mm	mm	mm	mm	mm	mm	mm	mm
JK-05	355	216										
JK-10	512	489	152	275	133	32	25	125	70	15	17.5	65
JK-20	588	557	152	275	133	32	25	125	70	15	17.5	65
JK-30	626	560	230	366	202	32	25	125	70	15	17.5	65
JK-50	741	680	230	366	202	32	25	125	70	15	17.5	65
JK-75	771	680	230	366	202	32	25	125	70	15	17.5	65

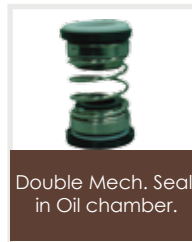
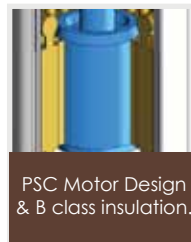
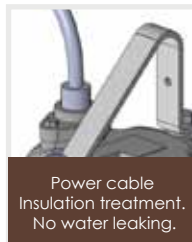
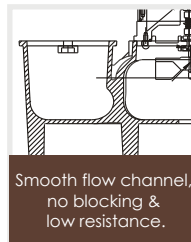
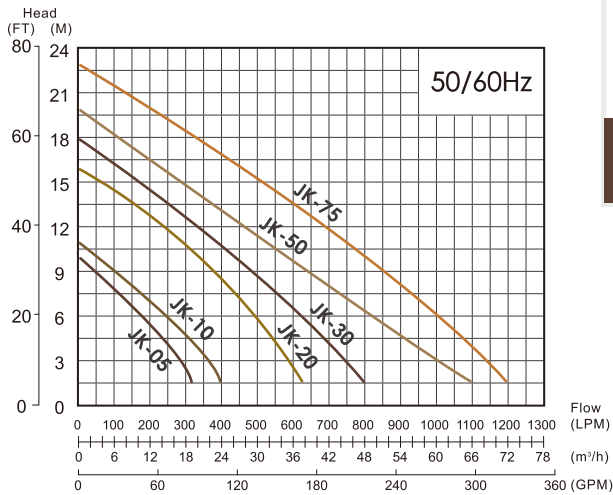

Specifications

Model No.	Output		Outlet		Solid Pass Dia(mm)	Max Flow (LPM)	LPM Flow @ Head					Max Head (M)	Dimension L x W x H(mm)	Weight Kg
	HP	kW	mm	inch			3M	6M	9M	12M	15M			
JK-05	1/2	0.4	50	2"	30	320	290	180	50	-	-	10	216 x 127 x 355	14
JK-10	1	0.75	50	2"	30	410	370	250	100	-	-	11	316 x 187 x 441	21
JK-20	2	1.5	80	3"	35	630	590	490	380	240	55	16	385 x 255 x 517	35
							3M	5M	10M	15M	20M			
JK-30	3	2.2	80	3"	35	800	750	670	440	180	-	18	385 x 255 x 255	36
JK-50	5	3.7	100	4"	45	1100	1000	880	590	290	-	20	486 x 290 x 629	55
JK-75	7.5	5.5	100	4"	50	1200	1150	1050	800	520	190	23	419 x 290 x 659	60