

Construction

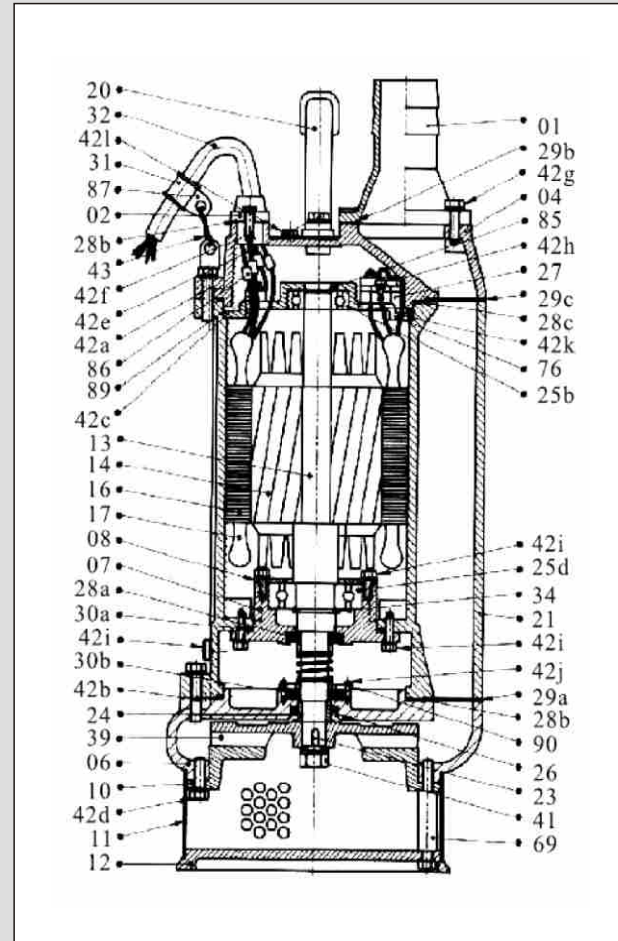

NO	Description	Material
1	Hose Tail	AC
2	Cable Gland	Fiber Plastic
4	Upper Cover	FC200
6	Pump Casing	FCD450
7	Bearing Block	FC200
8	Bearing Disc	SPC
10	Inlet Plate	FCD450
11	Strainer	SUS304
12	Bottom Plate	FCD450
13	Shaft	SUS420J2
14	Rotor	Silicon Steel
16	Stator	Silicon Steel
17	Coil	
20	Handle	SUS304
21	Motor Frame	FC200
23	Key	SUS304
24	Shaft Sleeve	SUS420J2
25a-b	Bearing	Ball Bearing
26	Oil Seal	NBR
27	Motor Protector	
28a-c	O-Ring	NBR
29a-b	Gasket	NBR
30a	Mech. Seal	CE/CA
30b	Mech. Seal	SIC/SIC
31	Cable Sleeve	NBR
32	Cable	
34	Collar	SC40
39	Impeller	HCR
41	Nut	SUS304
42a-1	Screw	SUS304
43	Steel Ring	SUS304
69	Bolt	SUS304
87	Grip	SUS304
89	Spring	SC40
90	Block Cover	SPC



KT/KR
INDUSTRIAL PUMP

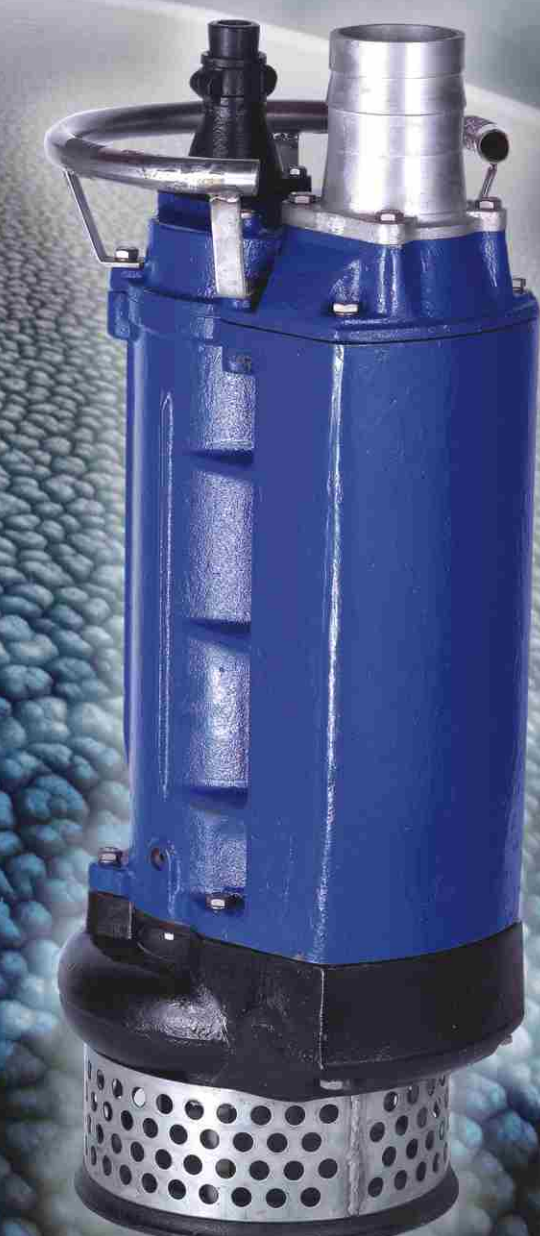

SUBMERSIBLE
CONTRACTOR
DEWATERING PUMPS

KT/KR

FEATURES:

- Completely water-tight cable entry sealed epoxy resin.
- Durable cast iron outer in semi-interior construction case achieves superior heat dissipation.
- Stainless steel strainer.
- Oil - free hermetically sealed, with built-in thermal overload protector. 3 phase, 2 pole, 50Hz 2850rpm and 60Hz 3450rpm, Insulation Class F= 155 °C,
- Protection Type IP68.
- Inlet Plate & Pump Casing are made of wear-resistant ductile iron to withstand very abrasive liquids.
- Max. liquid temperature : 40°C (104° F)
- Depth submerged is down to 10M

APPLICATIONS:

- General construction & civil engineering application.
- Tunnel & subway construction, mining and reclamation operation.
- Deep-well pre-dewatering.
- Popular usage in tunnel, subway and river construction, mining and reclamation operation for Deep well pre-dewatering.

KT 215~322

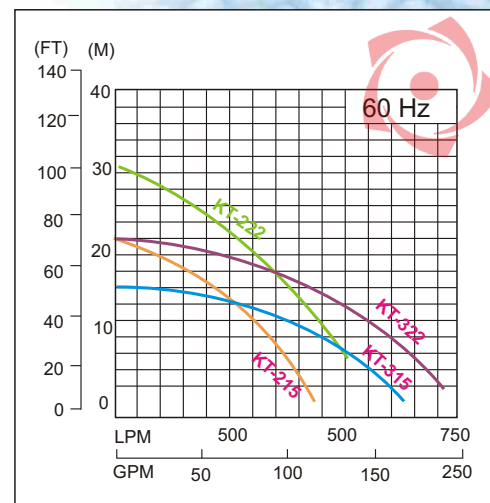
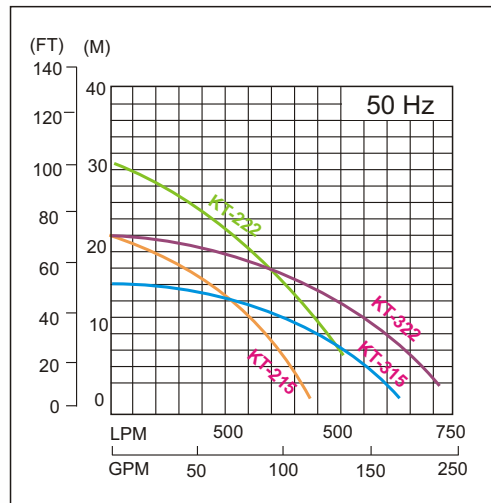

KT-237~455

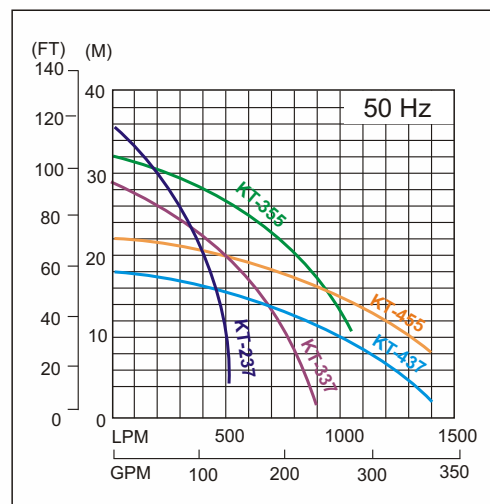
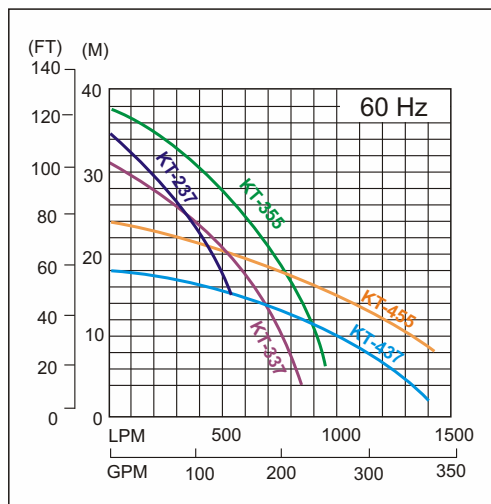

KT 475~6110

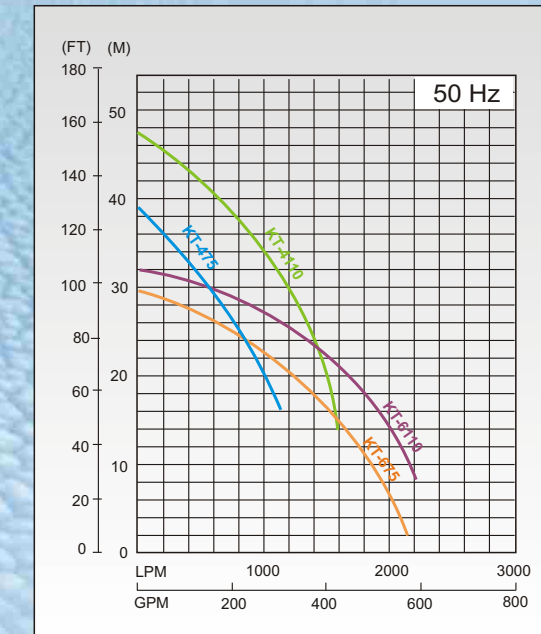
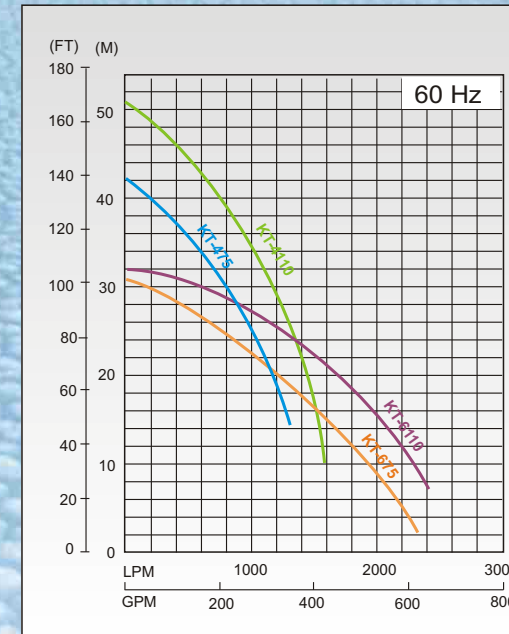

KR Series

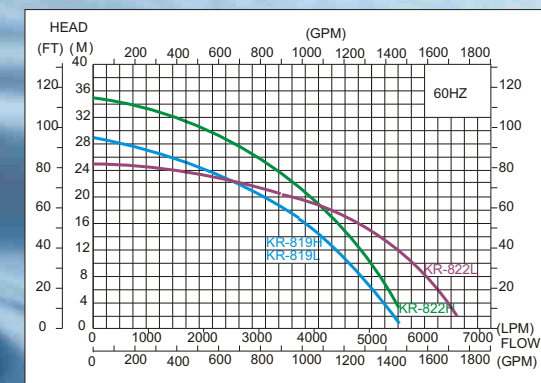
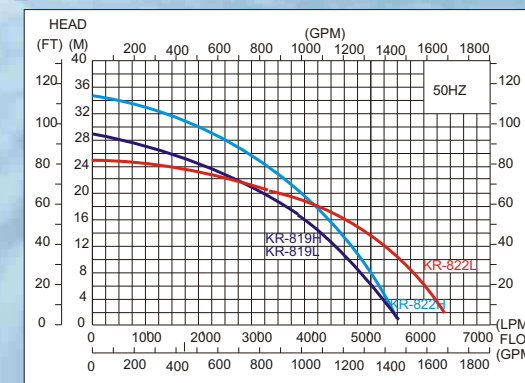

Specifications

Model	Output		Outlet		Rated		Maximum		Dimension L x W x H (mm)	Weight Kg	Pass Solids mm
	HP	kW	mm	Inch	Head(M)	Flow(l/m)	Head(M)	Flow(l/m)			
KT-215	2	1.5	50	2"	15	250	22	450	240x225x583	33	8
KT-222	3	2.2	50	2"	20	300	27	500	240x225x583	38	8
KT-315	2	1.5	80	3"	8	500	16	650	240x225x609	33	10
KT-322	3	2.2	80	3"	10	600	20	800	240x225x609	38	10
KT-237	5	3.7	50	2"	20	280	36	500	283x252x635	62	10
KT-337	5	3.7	80	3"	18	500	30	900	283x252x635	62	10
KT-437	5	3.7	100	4"	11	800	18	1500	283x252x635	62	15
KT-355	7.5	5.5	80	3"	18	700	32	1200	306x259x680	77	10
KT-455	7.5	5.5	100	4"	15	950	22	1700	306x529x680	77	15
KT-475	10	7.5	100	4"	30	800	40	1500	377x342x892	127	15
KT-675	10	7.5	150	6"	15	1600	30	2200	377x342x892	127	15
KT-4110	15	11	100	4"	35	1000	48	1600	377x342x892	140	15
KT-6110	15	11	150	6"	20	1700	32	2400	377x342x892	140	15
KR-819H	25	19	200	8"	20	3000	29	5500	580x540x1294	395	30
KR-819L	25	19	200	8"	15	4000	29	5500	580x540x1294	395	30
KR-822H	30	22	200	8"	30	2000	35	5500	580x540x1294	410	30
KR-822L	30	22	200	8"	15	5000	25	6500	580x540x1294	410	30