



MT Series

Booster Pressure Pumps

MT-Series are mini horizontal centrifugal pumps, with a wide range of applications in domestic water supply.

FEATURES:

- Multi-stage Design: Provides steady, quiet, vibration free
- Casing Seal: Reliable high pressure sealing with easy disassembly for maintenance or repair
- Mechanical Seal: A variety of face materials and plasterers to match application needs.
- With Close coupled IP55/54 protection design.
- Easy for maintenance and installation



MT-42-T24

APPLICATIONS:

- Fire fighting System
- Booster Service, Cooling System
- Clean water's transfer, garden sprinkler
- Water treatment, Circulation, Reverse osmosis
- Industrial Cleaning, Conveyance, circulation of liquid, Reverse osmosis





Construction

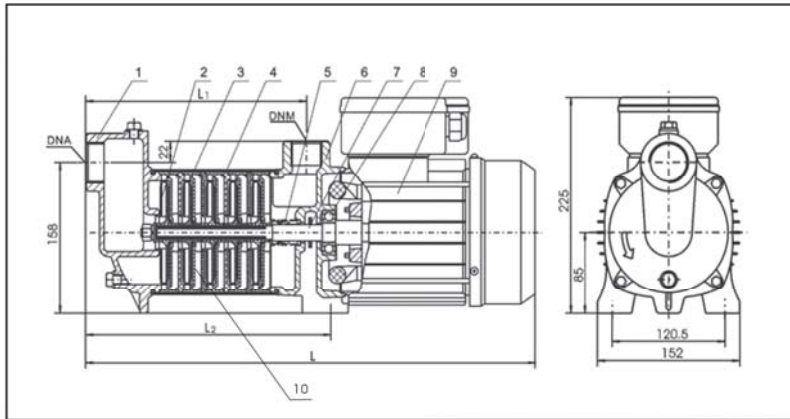

NO	Description	Material
1	Inlet Body	Cast Iron
2	Impeller	PPO
3	Guide Plate	NBR
4	Casing	SUS304
5	Mechanical Seal	CA/CE
6	Outlet Body	Cast Iron
7	Pump Shaft	SUS304
8	Bearing	CNM5K
9	Motor	Laminated Steel + Wiring

Specifications

Model	Output		Outlet		Rated		Maximum		Dimension L x W x H (mm)	Weight Kg
	HP	W	mm	Inch	Head(M)	Flow(l/m)	Head(M)	Flow(l/m)		
MT-43	1	750	32	1-1/4"	30	65	39	110	384x170x210	10
MT-44	1 1/3	1000	32	1-1/4"	40	65	53	110	408x170x210	10
MT-45	2	1500	32	1-1/4"	50	65	66	110	470x170x210	10
MT-46	2	1500	32	1-1/4"	60	65	79	110	495x170x210	11
MT-82	1 1/2	1100	32	1-1/4"	18	133	21	300	435x152x225	20
MT-83	1 1/2	1100	32	1-1/4"	28	133	32	300	474x152x225	21
MT-84	2	1500	32	1-1/4"	37	133	42	300	513x152x225	22
MT-85	3	2200	32	1-1/4"	46	133	53	300	552x152x225	24

Model	POWER (HP)	Connection	Suction (M)	Pressure	Max. Capacity (L/Min.)	Water Output (TAP)	No. of Bathroom
MT-43-T60	1	1**1"	9	3 - 4.2. kg/cm ²	150	8-12	8-12
MT-43-T100	1	1**1"		3 - 4.2. kg/cm ²	170	12-16	10-18
MT-44-T100	1-1/3	1**1"		3 - 4.2. kg/cm ²	170	12-16	10-18
MT-45-T100	2	1**1"		3 - 4.2. kg/cm ²	170	12-16	10-18
MT-46-T100	2	1**1"		3 - 4.2. kg/cm ²	170	12-16	10-18
MT-46-T200	2	1**1"		3 - 4.2. kg/cm ²	170	12-16	15-22
MT-82-T24	1-1/2	1-1/2**1-1/4"		2.4 - 3.6kg/cm ²	320	25-32	28-38
MT-83-T24	1-1/2	1-1/2**1-1/4"		2.4 - 3.6kg/cm ²	320	25-32	28-38
MT-83-T60	1-1/2	1-1/2**1-1/4"		2.4 - 3.6kg/cm ²	320	25-32	28-38
MT-84-T100	2	1-1/2**1-1/4"		2.4 - 3.6kg/cm ²	340	25-32	28-38
MT-84-T200	2	1-1/2**1-1/4"		2.4 - 3.6kg/cm ²	340	28-36	32-42
MT-85-T200	3	1-1/2**1-1/4"		2.4 - 3.6kg/cm ²	340	28-36	32-42

Remarks: MT-T that connects by water Tank is automatic booster set. Which can be applied on the site of castle, guest house, resort, hotel, apartment, factory.....

Performance

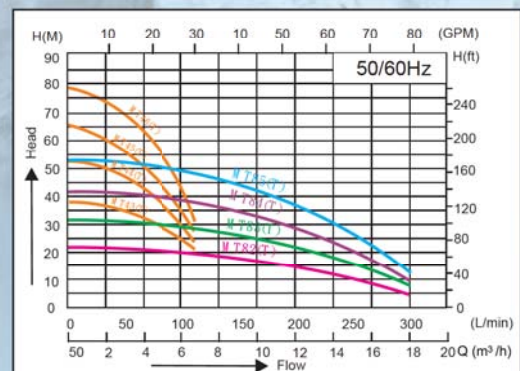

Hung Pump Group

16 Lien-Ming Street, Ba-De City 334,
Taoyuan, Taiwan
TEL:(886) -3-371-3969
FAX:(886) -3-371-3996
E-MAIL:info@pumps.com.tw