



www.pumps.com.tw

SW-60/120/250

High Pressure Application up to 60°C

Liquid temperature : 0 °C to 60 °C / +32 °F to +140 °F

HP range : 0.75 to 2.5 HP / 600 W to 1850 W

pH : 6 to 8

Protection class : IP55

Insulation class : F



Transferring water



Air condition/
Cooling/Industrial
cleaning system



RO Drinking
Water Supply

HUNG PUMP GROUP

Home Booster Pump

Features

- (1) Stainless steel impeller, Pump body and pump cover.
- (2) High pressure.

Dimension			
Model	A	B	C
	mm	mm	mm
SW-60	360	245	275
SW-120	360	245	275
SW-250	366	213	253

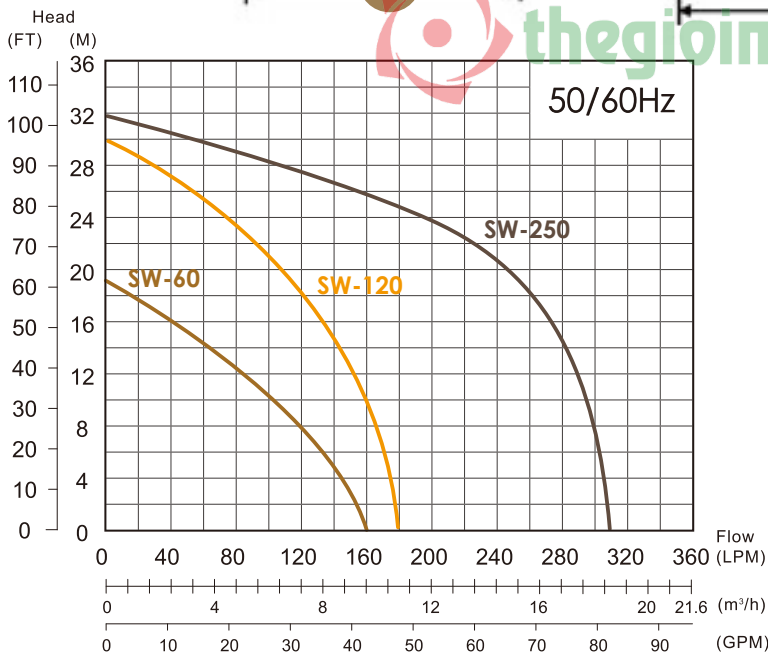
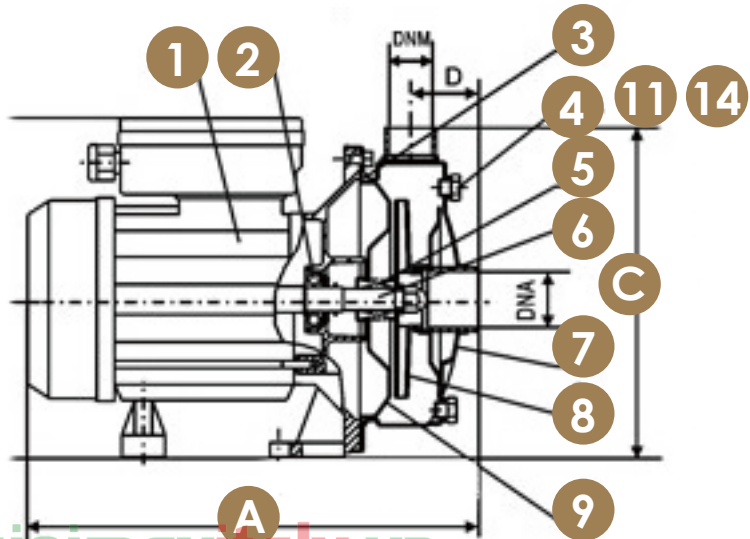

Construction		
No.	Description	Materials
1	Motor	Laminated Steel + Wiring
2	Bearing	
3	O-ring	NBR
4	Plug	SUS304
5	Mechanical Seal	CA/CE
6	Pump Shaft	SUS
7	Casing	SUS304
8	Impeller	SUS304
9	Pump Cover	SUS304

Specifications

Model No.	Output		Outlet		Max Flow (LPM)	LPM Flow @ Head					Max Head (M)	Dimension L x W x H (mm)	Weight Kg
	HP	W	mm	inch		5M	10M	15M	20M	25M			
SW-60	0.75	600	25	1"	160	140	100	53	-	-	19	360x245x275	9.4
SW-120	1.3	1000	25	1-1/4" * 1"	180	175	160	140	110	65	30	360x245x275	15.5
SW-250	2.5	1850	32	1-1/2" * 1-1/4"	310	305	295	285	245	180	32	366x213x253	20