

**GIRANTE SEMI-VORTEX
SEMI-VORTEX IMPELLER
ROUE SEMI-VORTEX**

CURVE DI PRESTAZIONE • PERFORMANCE CURVES • COURBES DE PERFORMANCE



TABELLA PRESTAZIONI • PERFORMANCE TABLE • TABLEAU DE PERFORMANCES

Modello Model Modèle	P ₂		Q = Portata / Flow rate / Débit												
	[HP]	[kW]	100 m ³ /h 6	150 9	200 12	300 18	400 24	500 30	550 33	600 36	700 42	750 45	900 54	1000 60	
50DVS51.5	2	1.5	18,8	16,6	14,3	10,7	-	-	-	-	-	-	-	-	

H = Prevalenza / Head / Hauteur manométrique totale [m]

IDRAULICA • HYDRAULIC • HYDRAULIQUE

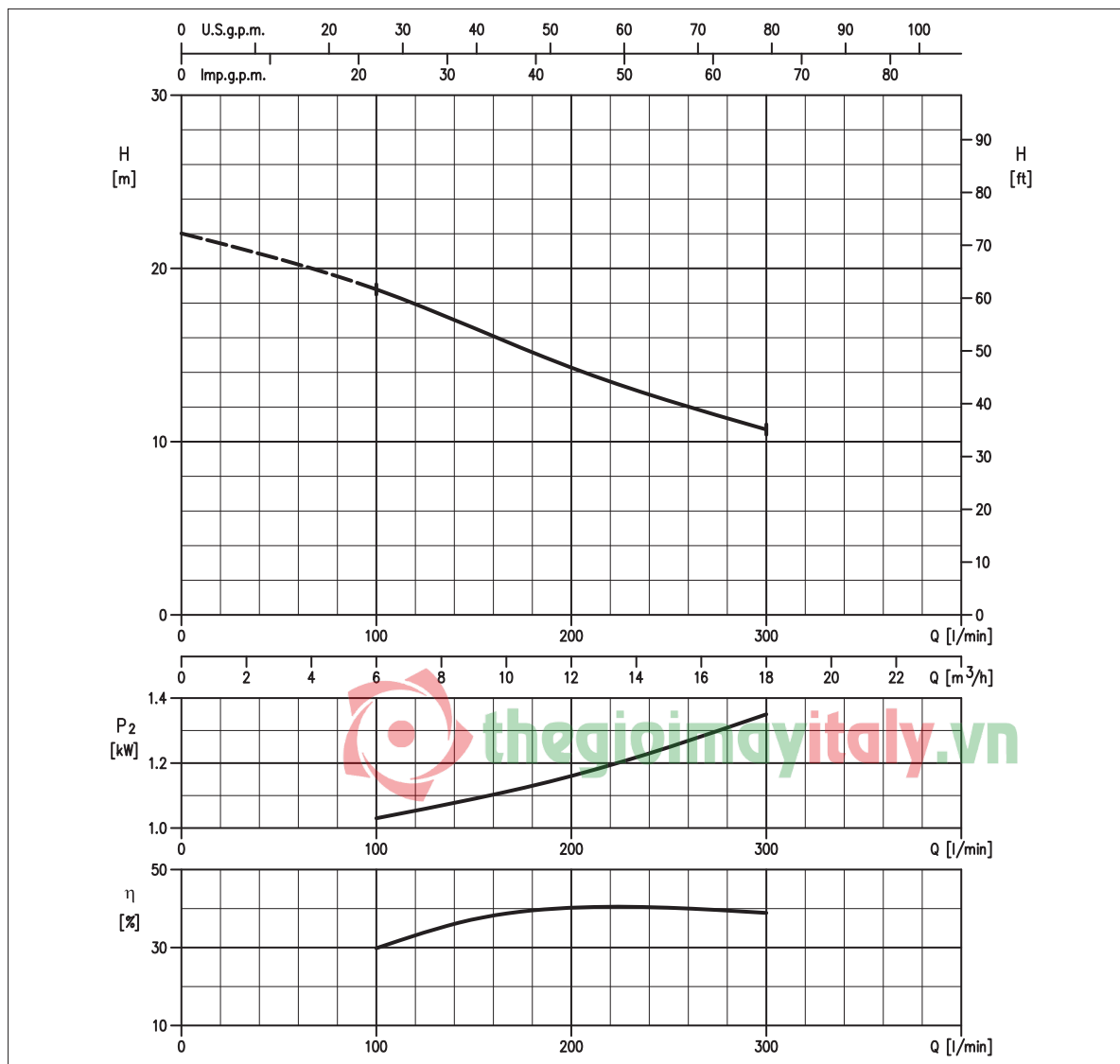
Girante Impeller Roue	SEMI-VORTEX ANTI INTASAMENTO NON-CLOGGED SEMI-VORTEX SEMI-OUVERTE AVEC ANTI COLMATAGE
Mandata Flanges Brides	DN 6.2"
Massimo diametro passaggi liberi Maximum solid diameter Passage libre maximum	21 mm
Temperatura massima del liquido Maximum liquid temperature Température maximale du liquide	40°C
Doppia tenuta meccanica Double mechanical seal Double garniture mécanique	SiC/SiC/NBR Cer/Carb/NBR

TIPO POMPA • PUMP TYPE • TYPE DE POMPE

Peso Weight Poids	27 kg	Costruzione Construction Construction	GHISA CAST IRON FONTE
-------------------------	--------------	---	--------------------------------------

MOTORE • MOTOR • MOTEUR

Tensione Power Tension	380 - 415V ±10%, 50 Hz	Cavo Cable Câble	6 m
Avviamento ora Starts per hour Nombre de démarrages par huere	10	P ₂	1.5 kW
Classe di isolamento Insulation class Classe d'isolation	F	Corrente di avviamento Start Current Ampérage au démarrage	20,5 A 21,1 A 22,5 A
Grado di protezione Protection degree Indice de protection	IP 68	Corrente 100% Current 100% Ampérage 100%	3,7 A 3,3 A 3,3 A
		Velocità di rotazione (rpm) Rotation speed (rpm) Vitesse de rotation (rpm)	2850



DIMENSIONI • DIMENSIONS • DIMENSIONS

RICAMBI • REPLACEMENT PARTS • PIÈCES DE RECHANGE



TABELLA DIMENSIONI • DIMENSIONS TABLE • TABLEAU DE DIMENSIONS

DA	Modello / Model / Modèle	Fig.	Tipo Flangia / Flanges type / Type bride	[kW]	DA	A	B	C	D	E	F	H	DE	J	L1 (*)	CL [m]	Peso / Weight / Poids [kg]
50	50DVS51.5	1	Ovale • Oval • Ovale	1.5	G2	249	171	163	86	125	82	439	96	-	105	6	27

001	Corpo pompa - Pump casing - Corps de la pompe
021	Girante - Impeller - Roue
039	Linguetta - Key - Languette
048	Dado girante - Nut - Écrou roue
111	Tenuta meccanica - Mechanical seal / Garniture mécanique
115-2	Anello OR - O-ring - Bague OR
115-3	Anello OR - O-ring - Bague OR
115-1	Anello OR - O-ring - Bague OR
117-1	Guarnizione - Gasket - Joint
117-2	Guarnizione - Gasket - Joint
117-3	Guarnizione - Gasket - Joint
811	Cavo - Cable - Câble
849-1	Cuscinetto - Bearing - Coussinet
849-2	Cuscinetto - Bearing - Coussinet
876	Termoprotettore - Auto cut - Protection thermique

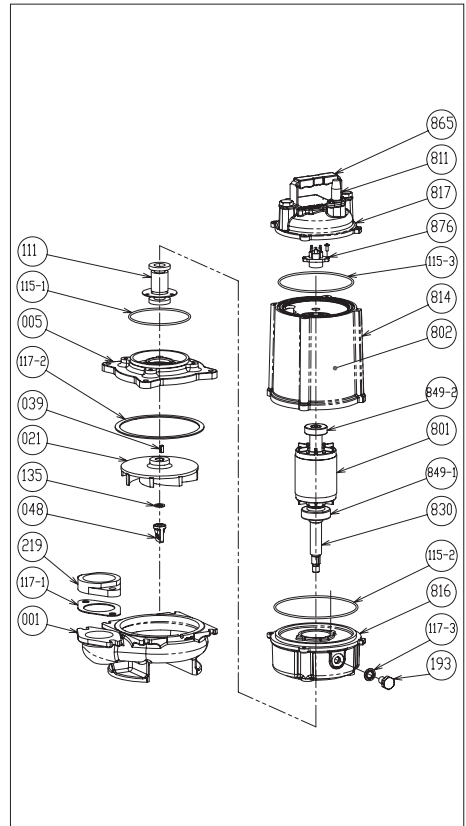
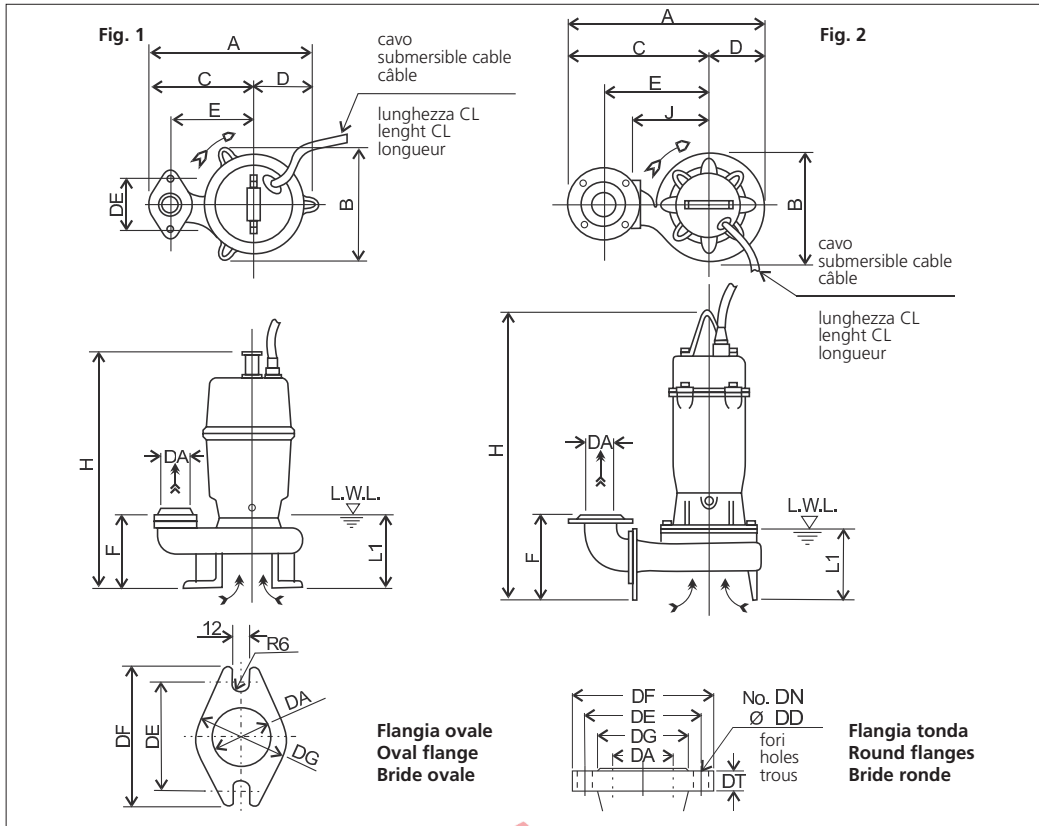

TABELLA DIMENSIONI QDC • QDC DIMENSIONS TABLE • TABLEAU DE DIMENSIONS QDC

DA	Modello / Model / Modèle	Fig.	Tipo Flangia / Flanges type / Type bride	[kW]	A	P1	P2	G1	G2	F	H1	H2	H3	L1 (*)	L6	BN1	BN2	D1	E1	QDC Mod.	[kg]
50	50DVS51.5	1	Ovale • Oval • Ovale	1.5	311	-	-	-	-	-	-	-	-	105	58	-	-	-	-	LS50	9

**MODELLO KIT SCIVOLO DISCESA (QDC)
QDC MODEL
MODÈLE KIT PIED D'ASSISE (QDC)
LS50**

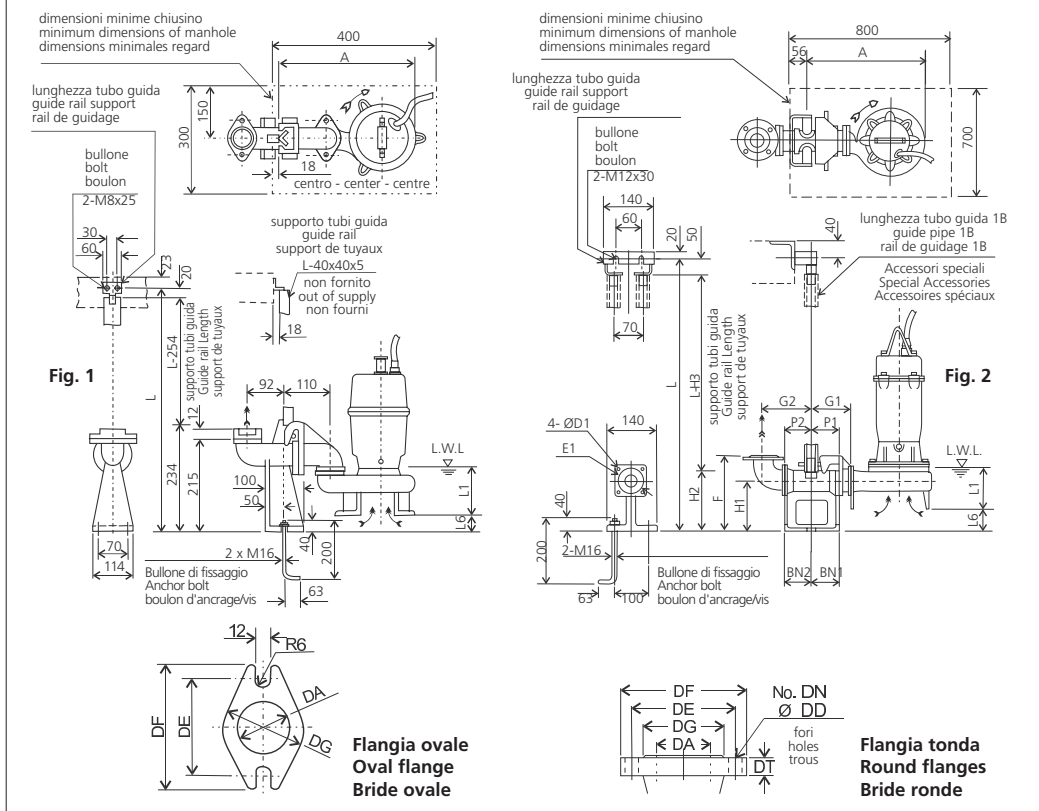
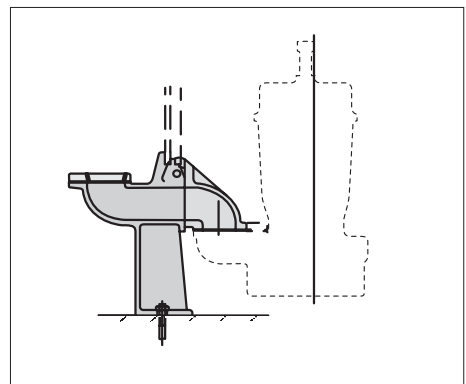
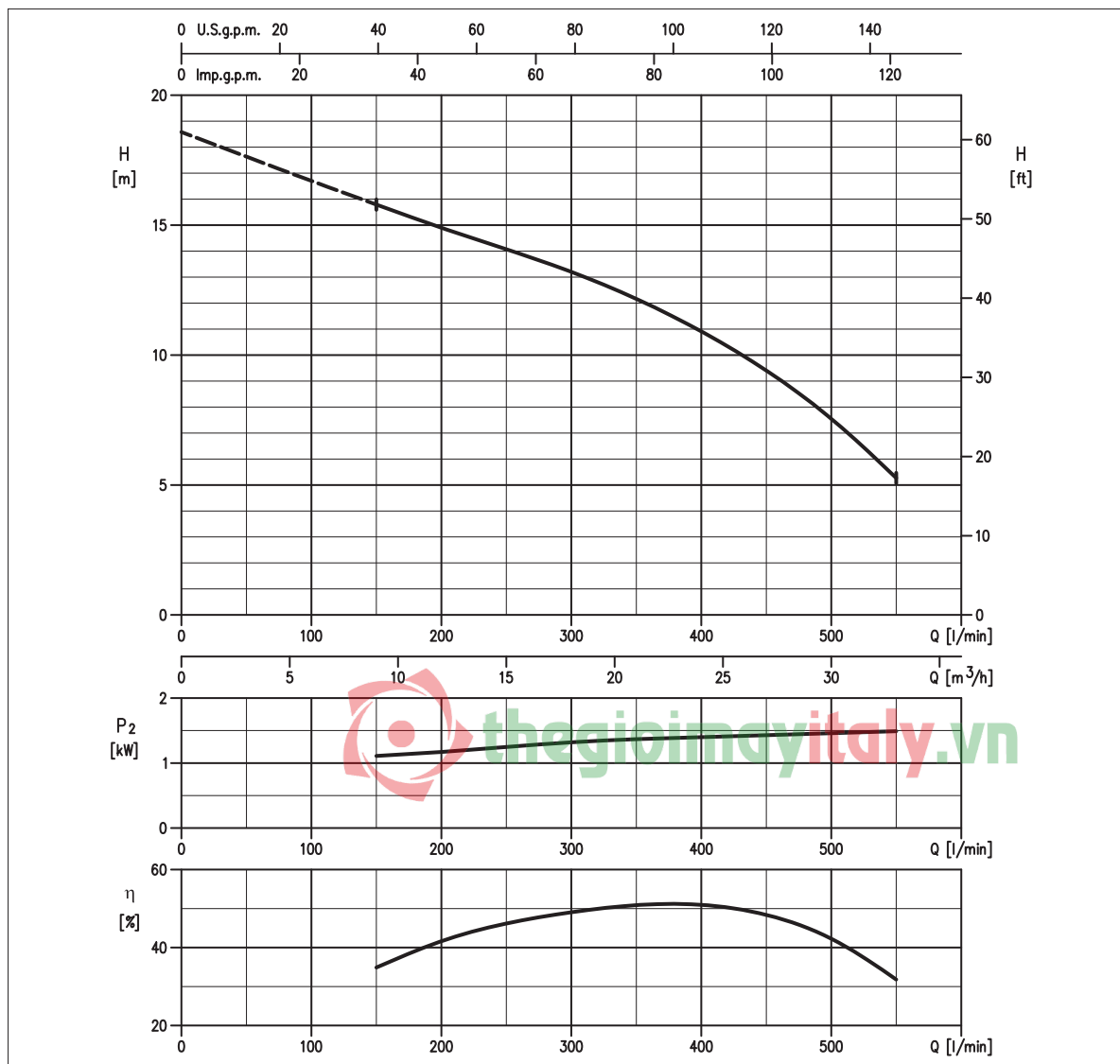

**GIRANTE SEMI-VORTEX
SEMI-VORTEX IMPELLER
ROUE SEMI-VORTEX**
CURVE DI PRESTAZIONE • PERFORMANCE CURVES • COURBES DE PERFORMANCE

TABELLA PRESTAZIONI • PERFORMANCE TABLE • TABLEAU DE PERFORMANCES

Modello Model Modèle	P ₂		Q = Portata / Flow rate / Débit												
	[HP]	[kW]	l/min 100	150	200	300	400	500	550	600	700	750	900	1000	
			m³/h 6	9	12	18	24	30	33	36	42	45	54	60	
65DVS51.5	2	1.5	-	15,8	14,9	13,2	10,9	7,6	5,3	-	-	-	-	-	

H = Prevalenza / Head / Hauteur manometrique totale [m]

IDRAULICA • HYDRAULIC • HYDRAULIQUE

Girante Impeller Roue	SEMI-VORTEX ANTI INTASAMENTO NON-CLOGGED SEMI-VORTEX SEMI-OUVERTE AVEC ANTI COLMATAGE
Mandata Flanges Brides	DN 65 mm
Massimo diametro passaggi liberi Maximum solid diameter Passage libre maximum	33 mm
Temperatura massima del liquido Maximum liquid temperature Température maximale du liquide	40°C
Doppia tenuta meccanica Double mechanical seal Double garniture mécanique	SiC/SiC/NBR Cer/Carb/NBR

TIPO POMPA • PUMP TYPE • TYPE DE POMPE

Peso Weight Poids	34 kg	Costruzione Construction Construction	GHISA CAST IRON FONTE
-------------------------	--------------	---	--------------------------------------

MOTORE • MOTOR • MOTEUR

Tensione Power Tension	380 - 415V ±10%, 50 Hz	Cavo Cable Câble	6 m
Avviamento ora Starts per hour Nombre de démarrages par huere	10	P ₂	1.5 kW
Classe di isolamento Insulation class Classe d'isolation	F	Corrente di avviamento Start Current Ampérage au démarrage	20,5 A 21,1 A 22,5 A
Grado di protezione Protection degree Indice de protection	IP 68	Corrente 100% Current 100% Ampérage 100%	3,70 A 3,30 A 3,30 A
		Velocità di rotazione (rpm) Rotation speed (rpm) Vitesse de rotation (rpm)	2850



DIMENSIONI • DIMENSIONS • DIMENSIONS

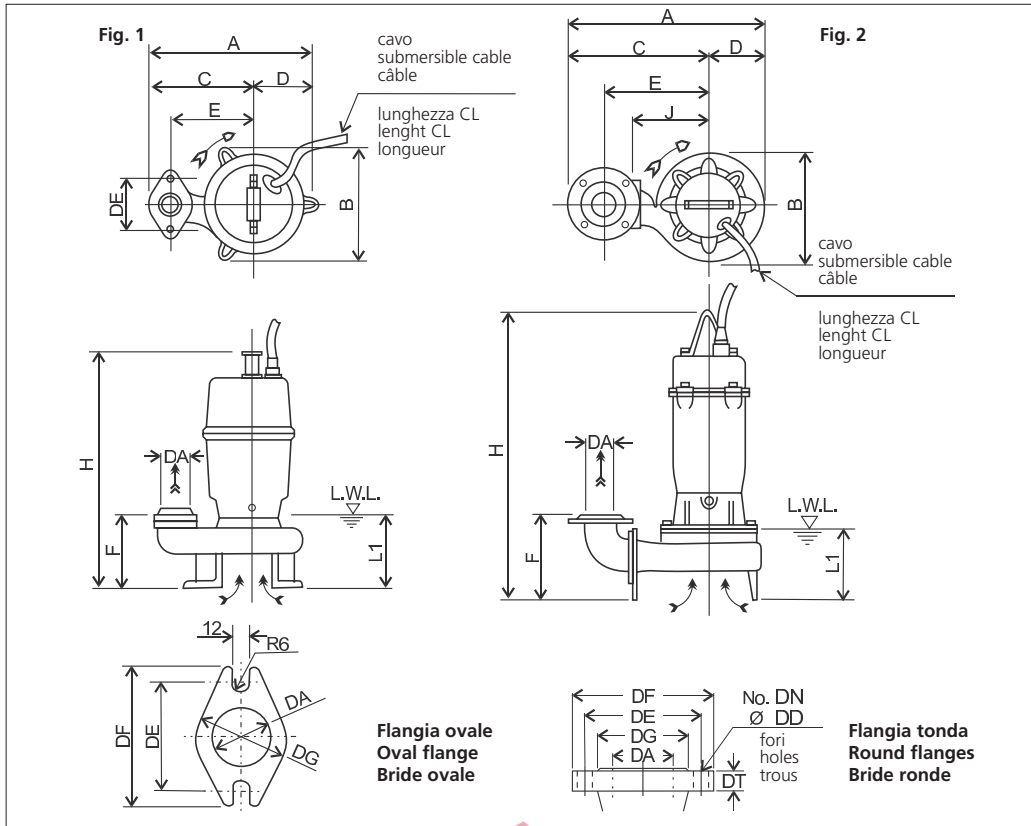

RICAMBI • REPLACEMENT PARTS • PIÈCES DE RECHANGE



TABELLA DIMENSIONI • DIMENSIONS TABLE • TABLEAU DE DIMENSIONS

DA	Modello Model Modèle	Fig.	Tipo Flangia Flanges type Type bride	[kW]	DA	A	B	C	D	E	F	H	DE	J	L1 (*)	CL [m]	Peso Weight Poids [kg]
65	65DVS52.2	2	Tonda • Round • Ronde	1.5	65	396	195	298	98	210	178	519	-	145	125	6	34

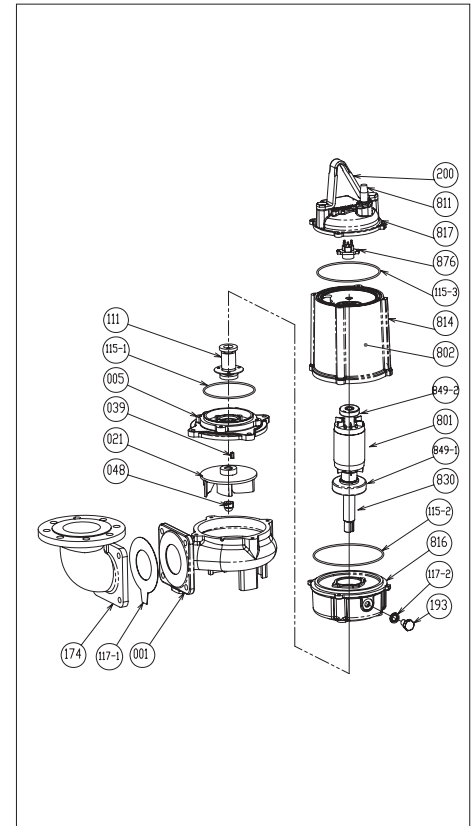
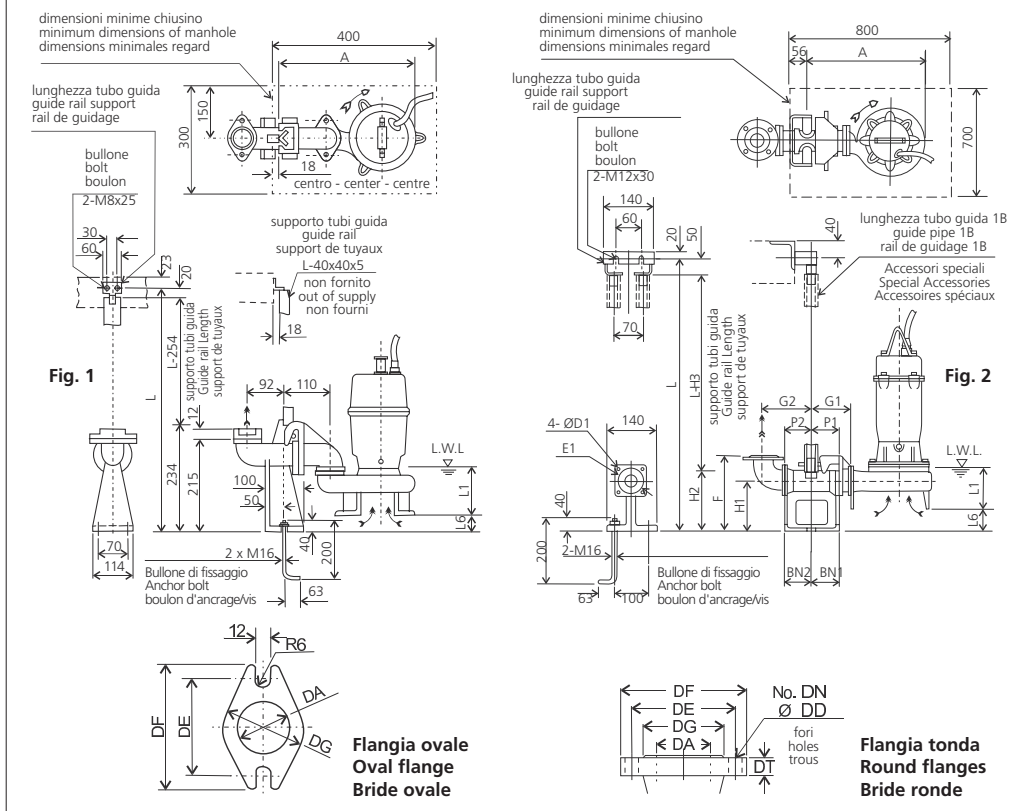

001	Corpo pompa - Pump casing - Corps de la pompe
021	Girante - Impeller - Roue
039	Linguetta - Key - Languette
048	Dado girante - Nut - Écrou roue
111	Tenuta meccanica - Mechanical seal Garniture mécanique
115-2	Anello OR - O-ring - Bague OR
115-3	Anello OR - O-ring - Bague OR
115-1	Anello OR - O-ring - Bague OR
117-1	Guarnizione - Gasket - Joint
117-2	Guarnizione - Gasket - Joint
811	Cavo - Cable - Câble
849-1	Cuscinetto - Bearing - Coussinet
849-2	Cuscinetto - Bearing - Coussinet
876	Termoprotettore - Auto cut - Protection thermique

**MODELLO KIT SCIVOLO DISCESA (QDC)
QDC MODEL
MODÈLE KIT PIED D'ASSISE (QDC)
LM65**



TABELLA DIMENSIONI QDC • QDC DIMENSIONS TABLE • TABLEAU DE DIMENSIONS QDC

DA	Modello Model Modèle	Fig.	Tipo Flangia Flanges type Type bride	[kW]	A	P1	P2	G1	G2	F	H1	H2	H3	L1 (*)	L6	BN1	BN2	D1	E1	QDC Mod. [kg]	
65	65DVS51.5	2	Tonda • Round • Ronde	1.5	363	75	95	120	160	250	145	190	240	125	72	75	95	12	140	LM65	14

GIRANTE SEMI-VORTEX SEMI-VORTEX IMPELLER ROUE SEMI-VORTEX

CURVE DI PRESTAZIONE • PERFORMANCE CURVES • COURBES DE PERFORMANCE

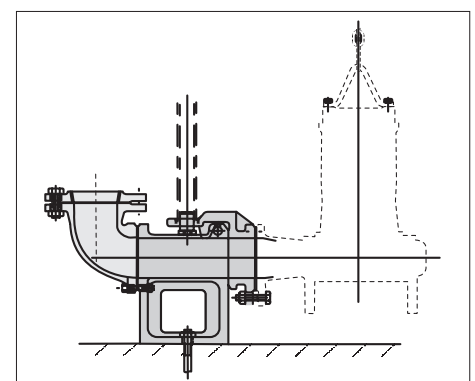

TABELLA PRESTAZIONI • PERFORMANCE TABLE • TABLEAU DE PERFORMANCES

Modello Model Modèle	P ₂		Q = Portata / Flow rate / Débit												
	[HP]	[kW]	100 m ³ /h 6	150 9	200 12	300 18	400 24	500 30	550 33	600 36	700 42	750 45	900 54	1000 60	
65DVS52.2	3	2.2	-	-	17,5	15,9	14,2	12,3	11,5	10,5	8,1	6,6	-	-	

H = Prevalenza / Head / Hauteur manometrique totale [m]

IDRAULICA • HYDRAULIC • HYDRAULIQUE

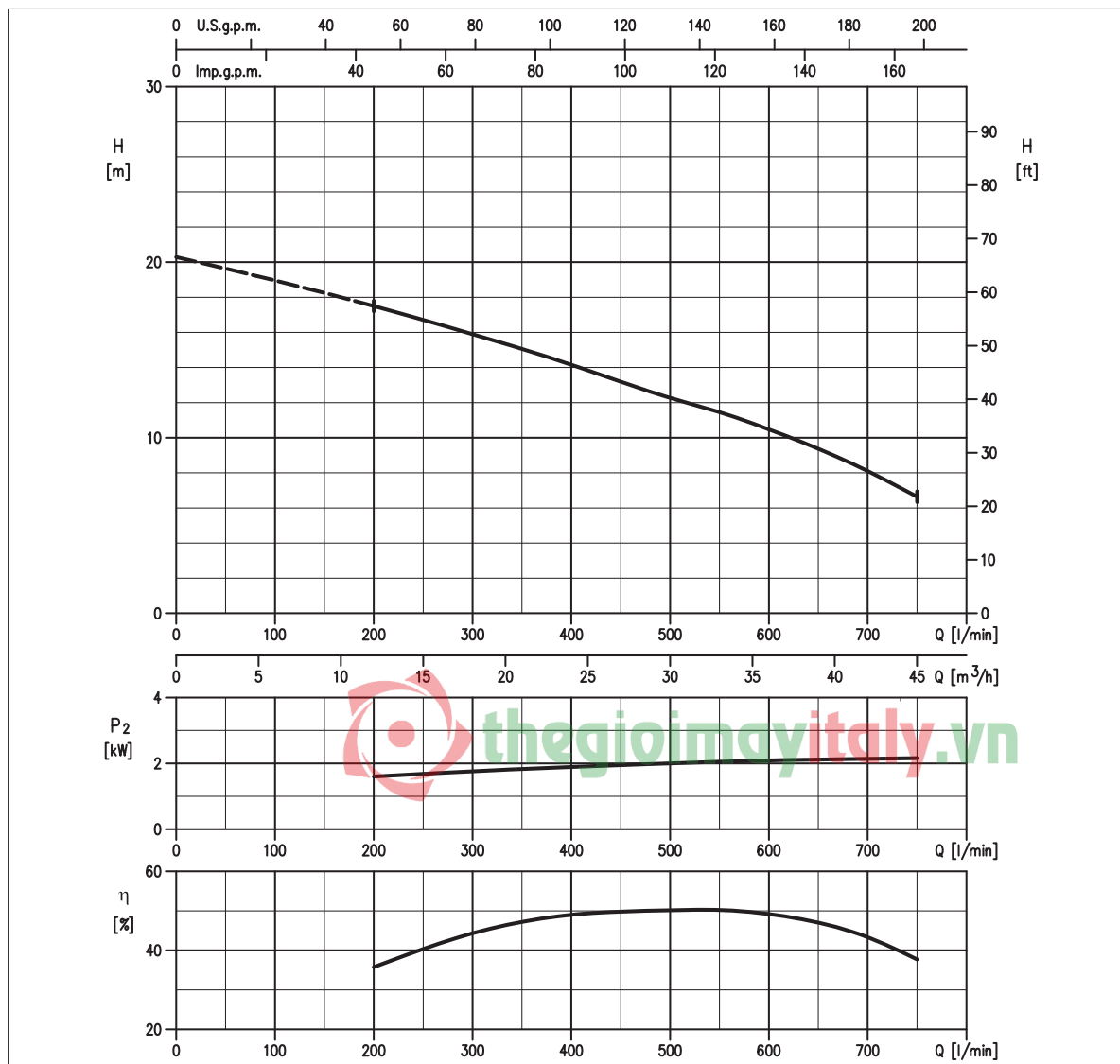
Girante Impeller Roue	SEMI-VORTEX ANTI INTASAMENTO NON-CLOGGED SEMI-VORTEX SEMI-OUVERTE AVEC ANTI COLMATAGE
Mandata Flanges Brides	DN 65 mm
Massimo diametro passaggi liberi Maximum solid diameter Passage libre maximum	41 mm
Temperatura massima del liquido Maximum liquid temperature Température maximale du liquide	40°C
Doppia tenuta meccanica Double mechanical seal Double garniture mécanique	SiC/SiC/NBR Cer/Carb/NBR

TIPO POMPA • PUMP TYPE • TYPE DE POMPE

Peso Weight Poids	50 kg	Costruzione Construction Construction	GHISA CAST IRON FONTE
-------------------------	--------------	---	--------------------------------------

MOTORE • MOTOR • MOTEUR

Tensione Power Tension	380 - 415V ±10%, 50 Hz	Cavo Cable Câble	10 m
Avviamento ora Starts per hour Nombre de démarrages par huere	10	P ₂	2.2 kW
Classe di isolamento Insulation class Classe d'isolation	F	Corrente di avviamento Start Current Ampérage au démarrage	380 V 400 V 415 V 28,7 A 30,0 A 31,5 A
Grado di protezione Protection degree Indice de protection	IP 68	Corrente 100% Current 100% Ampérage 100%	5,10 A 5,00 A 4,60 A
		Velocità di rotazione (rpm) Rotation speed (rpm) Vitesse de rotation (rpm)	2850



DIMENSIONI • DIMENSIONS • DIMENSIONS

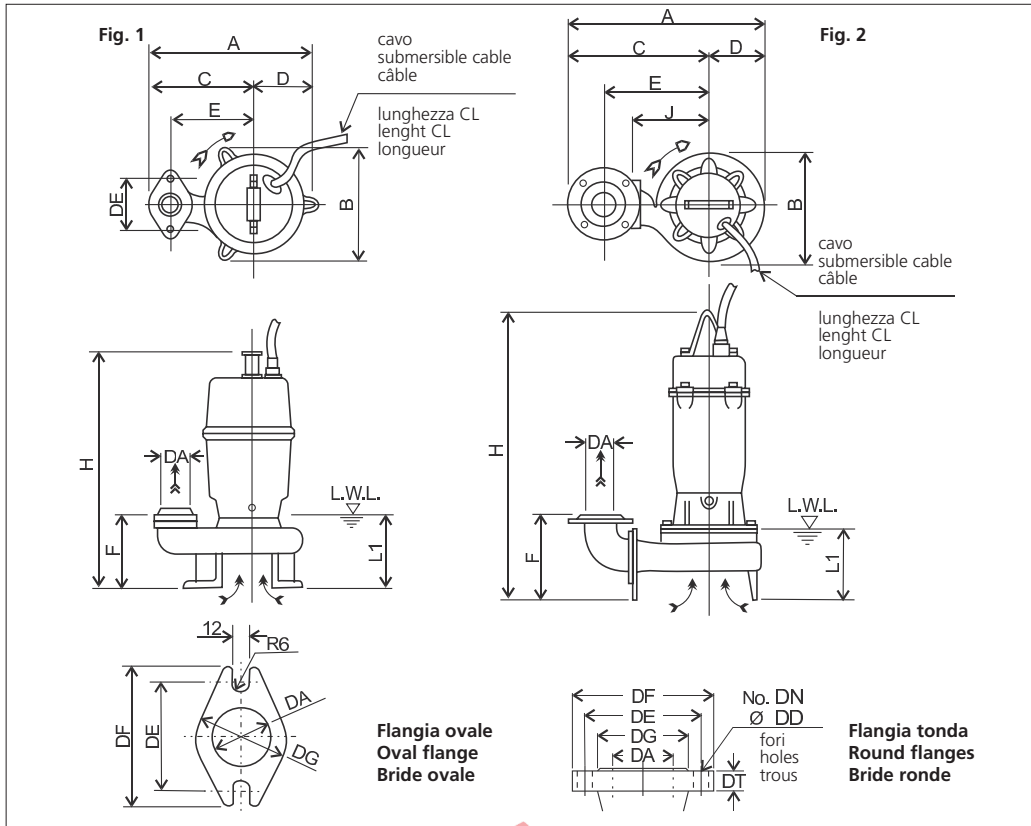

RICAMBI • REPLACEMENT PARTS • PIÈCES DE RECHANGE

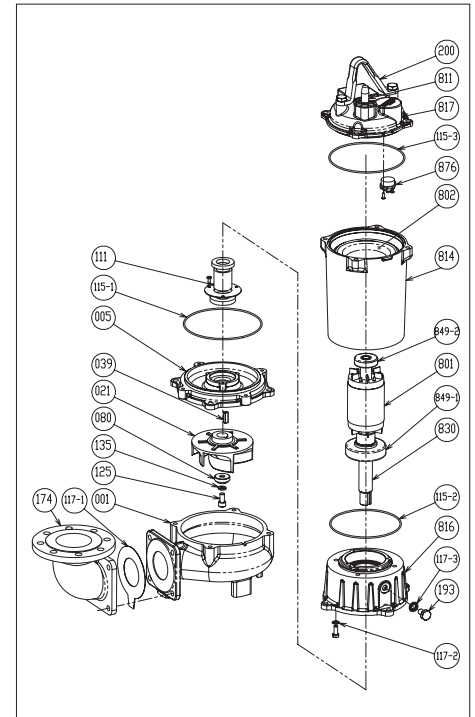

001	Corpo pompa - Pump casing - Corps de la pompe
021	Girante - Impeller - Roue
039	Linguetta - Key - Languette
080	Bussola - Bushing - Bague d'usure
111	Tenuta meccanica - Mechanical seal Garniture mécanique
115-2	Anello OR - O-ring - Bague OR
115-3	Anello OR - O-ring - Bague OR
115-1	Anello OR - O-ring - Bague OR
117-1	Guarnizione - Gasket - Joint
117-2	Guarnizione - Gasket - Joint
117-3	Guarnizione - Gasket - Joint
125	Vite - Screw - Vis
135	Rondella - Washer - Rondelle d'étanchiété
811	Cavo - Cable - Câble
849-1	Cuscinetto - Bearing - Coussinet
849-2	Cuscinetto - Bearing - Coussinet
876	Termoprotettore - Auto cut - Protection thermique

TABELLA DIMENSIONI • DIMENSIONS TABLE • TABLEAU DE DIMENSIONS

DA	Modello Model Modèle	Fig.	Tipo Flangia Flanges type Type bride	[kW]	DA	A	B	C	D	E	F	H	DE	J	L1 (*)	CL [m]	Peso Weight Poids [kg]
65	65DVS52.2	2	Tonda • Round • Ronde	2.2	65	427	227	313	114	225	201	643	-	160	155	10	50

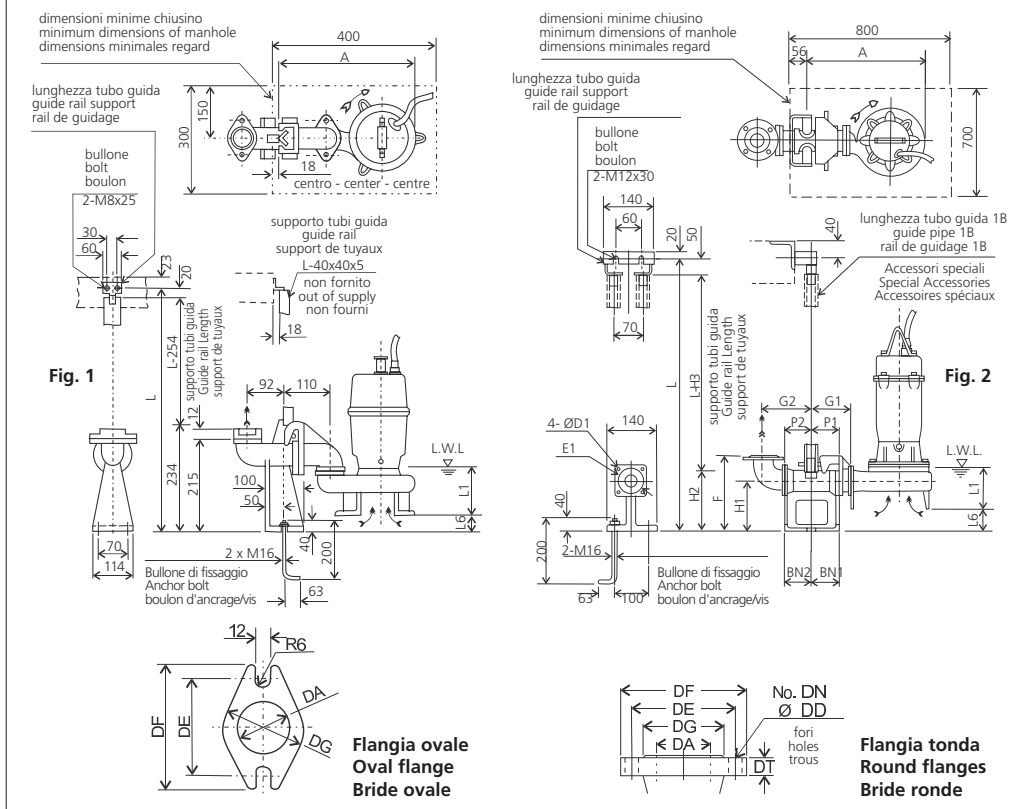

MODELLO KIT SCIVOLO DISCESA (QDC) QDC MODEL MODÈLE KIT PIED D'ASSISE (QDC) LM65



TABELLA DIMENSIONI QDC • QDC DIMENSIONS TABLE • TABLEAU DE DIMENSIONS QDC

DA	Modello Model Modèle	Fig.	Tipo Flangia Flanges type Type bride	[kW]	A	P1	P2	G1	G2	F	H1	H2	H3	L1 (*)	L6	BN1	BN2	D1	E1	QDC Mod. [kg]	
65	65DVS52.2	2	Tonda • Round • Ronde	2.2	394	75	95	120	160	250	145	190	240	155	49	75	95	12	140	LM65	14

GIRANTE SEMI-VORTEX SEMI-VORTEX IMPELLER ROUE SEMI-VORTEX

CURVE DI PRESTAZIONE • PERFORMANCE CURVES • COURBES DE PERFORMANCE

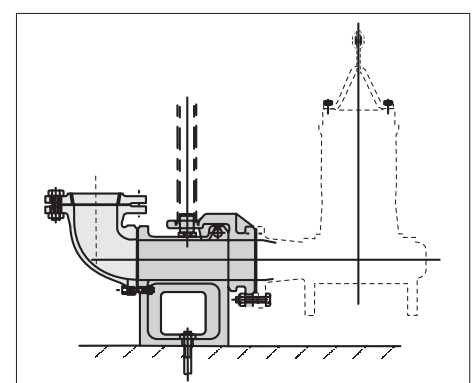

TABELLA PRESTAZIONI • PERFORMANCE TABLE • TABLEAU DE PERFORMANCES

Modello Model Modèle	P ₂		Q = Portata / Flow rate / Débit												
	[HP]	[kW]	l/min 100 m ³ /h 6	150 9	200 12	300 18	400 24	500 30	550 33	600 36	700 42	750 45	900 54	1000 60	
65DVS53.7	5	3.7	-	-	23,0	21,6	20,1	18,4	17,6	16,7	15,0	14,0	10,4	6,9	

H = Prevalenza / Head / Hauteur manométrique totale [m]

IDRAULICA • HYDRAULIC • HYDRAULIQUE

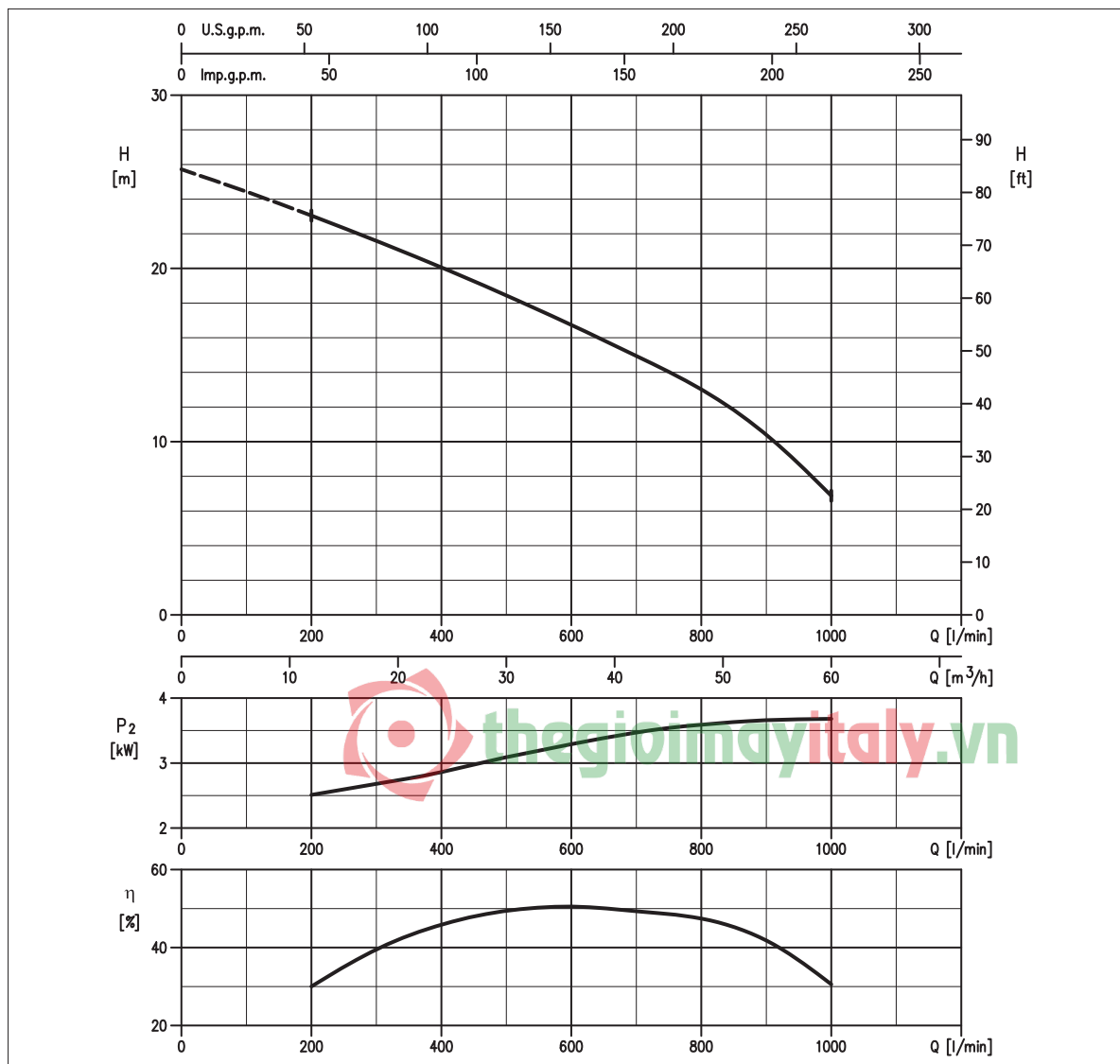
Girante Impeller Roue	SEMI-VORTEX ANTI INTASAMENTO NON-CLOGGED SEMI-VORTEX SEMI-OUVERTE AVEC ANTI COLMATAGE
Mandata Flanges Brides	DN 65 mm
Massimo diametro passaggi liberi Maximum solid diameter Passage libre maximum	41 mm
Temperatura massima del liquido Maximum liquid temperature Température maximale du liquide	40°C
Doppia tenuta meccanica Double mechanical seal Double garniture mécanique	SiC/SiC/NBR Cer/Carb/NBR

TIPO POMPA • PUMP TYPE • TYPE DE POMPE

Peso Weight Poids	59 kg	Costruzione Construction Construction	GHISA CAST IRON FONTE
-------------------------	--------------	---	--------------------------------------

MOTORE • MOTOR • MOTEUR

Tensione Power Tension	380 - 415V ±10%, 50 Hz	Cavo Cable Câble	10 m
Avviamento ora Starts per hour Nombre de démarrages par huere	10	P ₂	3.7 kW
Classe di isolamento Insulation class Classe d'isolation	F	Corrente di avviamento Start Current Ampérage au démarrage	51,2 A 51,0 A 53,0 A
Grado di protezione Protection degree Indice de protection	IP 68	Corrente 100% Current 100% Ampérage 100%	8,80 A 7,80 A 7,80 A
		Velocità di rotazione (rpm) Rotation speed (rpm) Vitesse de rotation (rpm)	2850



DIMENSIONI • DIMENSIONS • DIMENSIONS

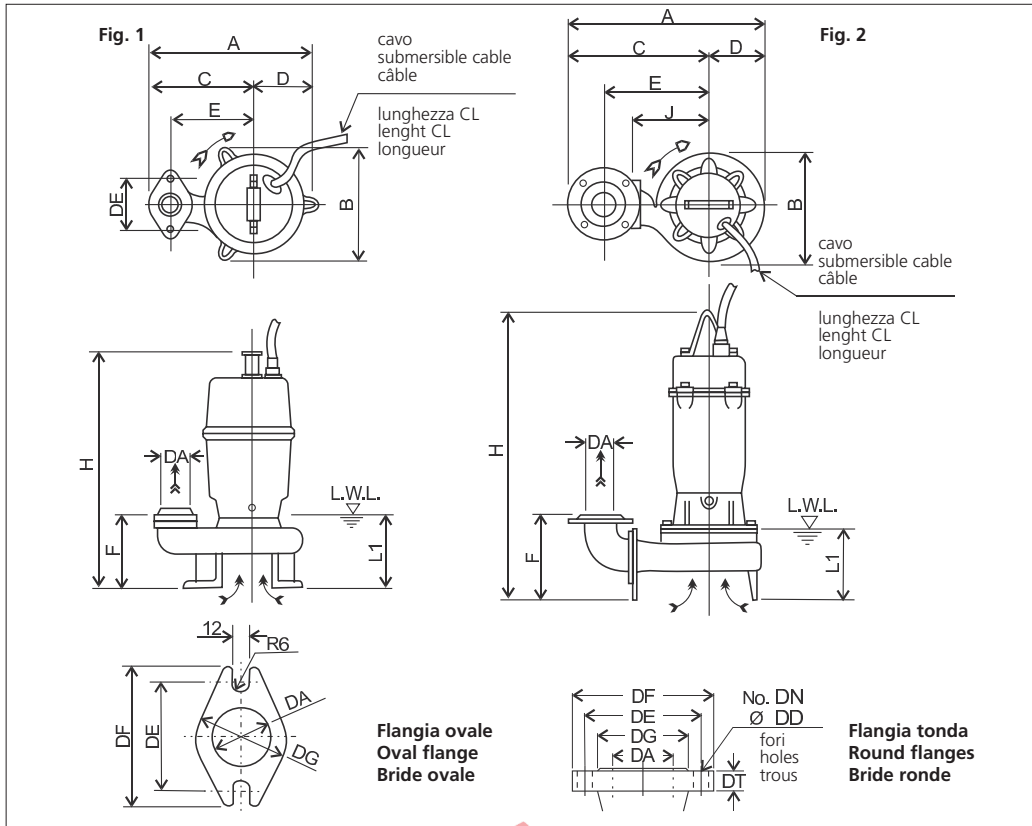

RICAMBI • REPLACEMENT PARTS • PIÈCES DE RECHANGE

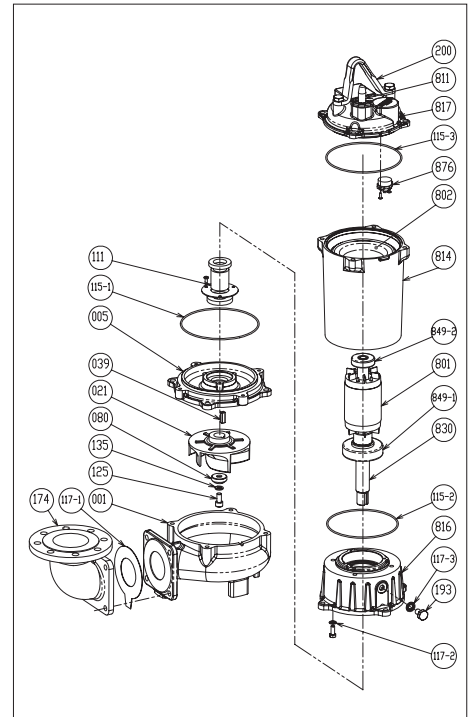

001	Corpo pompa - Pump casing - Corps de la pompe
021	Girante - Impeller - Roue
039	Linguetta - Key - Languette
080	Bussola - Bushing - Bague d'usure
111	Tenuta meccanica - Mechanical seal Garniture mécanique
115-2	Anello OR - O-ring - Bague OR
115-3	Anello OR - O-ring - Bague OR
115-1	Anello OR - O-ring - Bague OR
117-1	Guarnizione - Gasket - Joint
117-2	Guarnizione - Gasket - Joint
117-3	Guarnizione - Gasket - Joint
125	Vite - Screw - Vis
135	Rondella - Washer - Rondelle d'étanchiété
811	Cavo - Cable - Câble
849-1	Cuscinetto - Bearing - Coussinet
849-2	Cuscinetto - Bearing - Coussinet
876	Termoprotettore - Auto cut - Protection thermique

TABELLA DIMENSIONI • DIMENSIONS TABLE • TABLEAU DE DIMENSIONS

DA	Modello Model Modèle	Fig.	Tipo Flangia Flanges type Type bride	[kW]	DA	A	B	C	D	E	F	H	DE	J	L1 (*)	CL [m]	Peso Weight Poids [kg]
65	65DVS53.7	2	Tonda • Round • Ronde	3.7	65	427	227	313	114	225	201	643	-	160	155	10	59



TABELLA DIMENSIONI QDC • QDC DIMENSIONS TABLE • TABLEAU DE DIMENSIONS QDC

DA	Modello Model Modèle	Fig.	Tipo Flangia Flanges type Type bride	[kW]	A	P1	P2	G1	G2	F	H1	H2	H3	L1 (*)	L6	BN1	BN2	D1	E1	QDC Mod. [kg]	
65	65DVS53.7	2	Tonda • Round • Ronde	3.7	394	75	95	120	160	250	145	190	240	155	49	75	95	12	140	LM65	14

**MODELLO KIT SCIVOLO DISCESA (QDC)
QDC MODEL
MODÈLE KIT PIED D'ASSISE (QDC)
LM65**

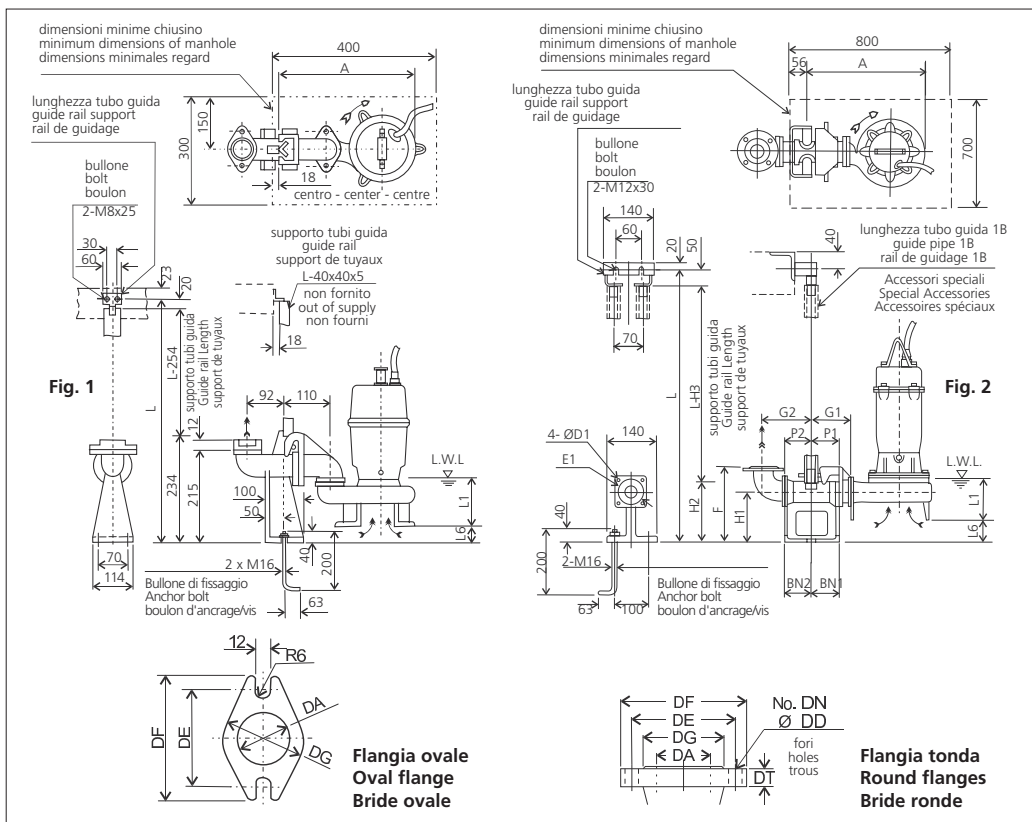
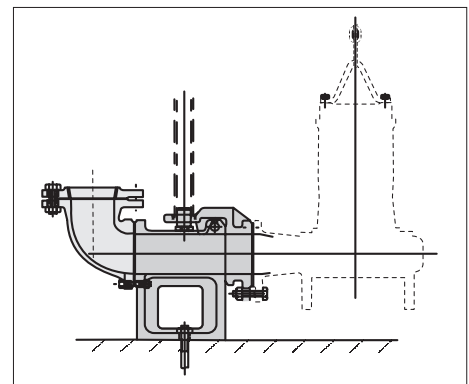

GIRANTE SEMI-VORTEX SEMI-VORTEX IMPELLER ROUE SEMI-VORTEX

CURVE DI PRESTAZIONE • PERFORMANCE CURVES • COURBES DE PERFORMANCE



TABELLA PRESTAZIONI • PERFORMANCE TABLE • TABLEAU DE PERFORMANCES

Modello Model Modèle	P ₂		Q = Portata / Flow rate / Débit												
	[HP]	[kW]	100 m³/h 6	150 9	200 12	300 18	400 24	500 30	550 33	600 36	700 42	750 45	900 54	1000 60	
80DVS51.5	2	1.5	-	15,8	14,9	13,2	10,9	7,6	5,3	-	-	-	-	-	

H = Prevalenza / Head / Hauteur manometrique totale [m]

IDRAULICA • HYDRAULIC • HYDRAULIQUE

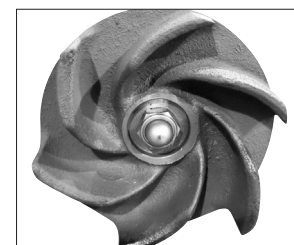
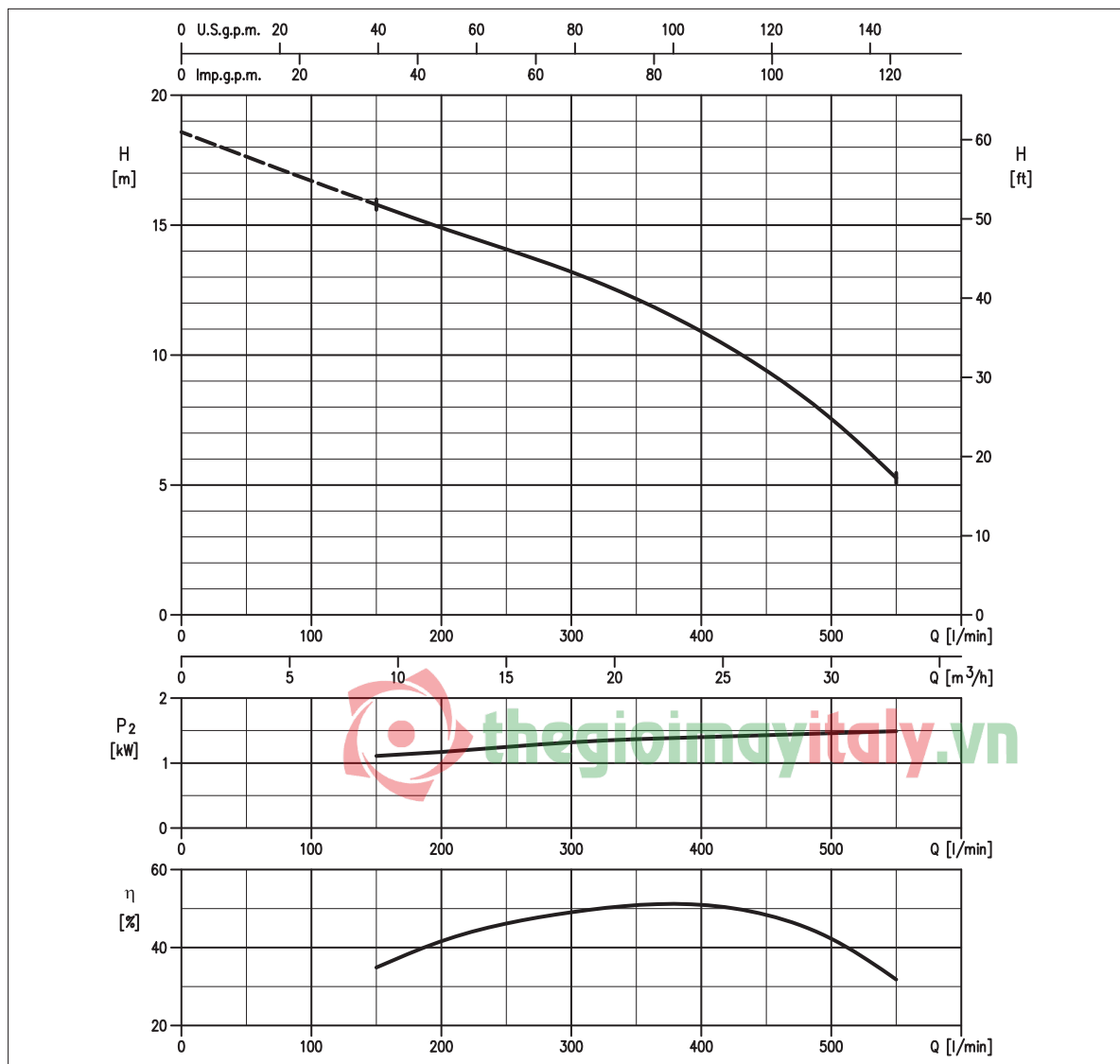
Girante Impeller Roue	SEMI-VORTEX ANTI INTASAMENTO NON-CLOGGED SEMI-VORTEX SEMI-OUVERTE AVEC ANTI COLMATAGE
Mandata Flanges Brides	DN 80 mm
Massimo diametro passaggi liberi Maximum solid diameter Passage libre maximum	41 mm
Temperatura massima del liquido Maximum liquid temperature Température maximale du liquide	40°C
Doppia tenuta meccanica Double mechanical seal Double garniture mécanique	SiC/SiC/NBR Cer/Carb/NBR

TIPO POMPA • PUMP TYPE • TYPE DE POMPE

Peso Weight Poids	35 kg	Costruzione Construction Construction	GHISA CAST IRON FONTE
-------------------------	--------------	---	--------------------------------------

MOTORE • MOTOR • MOTEUR

Tensione Power Tension	380 - 415V ±10%, 50 Hz	Cavo Cable Câble	10 m
Avviamento ora Starts per hour Nombre de démarrages par huere	10	P ₂	1.5 kW
Classe di isolamento Insulation class Classe d'isolation	F	Corrente di avviamento Start Current Ampérage au démarrage	20,5 A 21,1 A 22,5 A
Grado di protezione Protection degree Indice de protection	IP 68	Corrente 100% Current 100% Ampérage 100%	3,70 A 3,30 A 3,30 A
		Velocità di rotazione (rpm) Rotation speed (rpm) Vitesse de rotation (rpm)	2850



DIMENSIONI • DIMENSIONS • DIMENSIONS

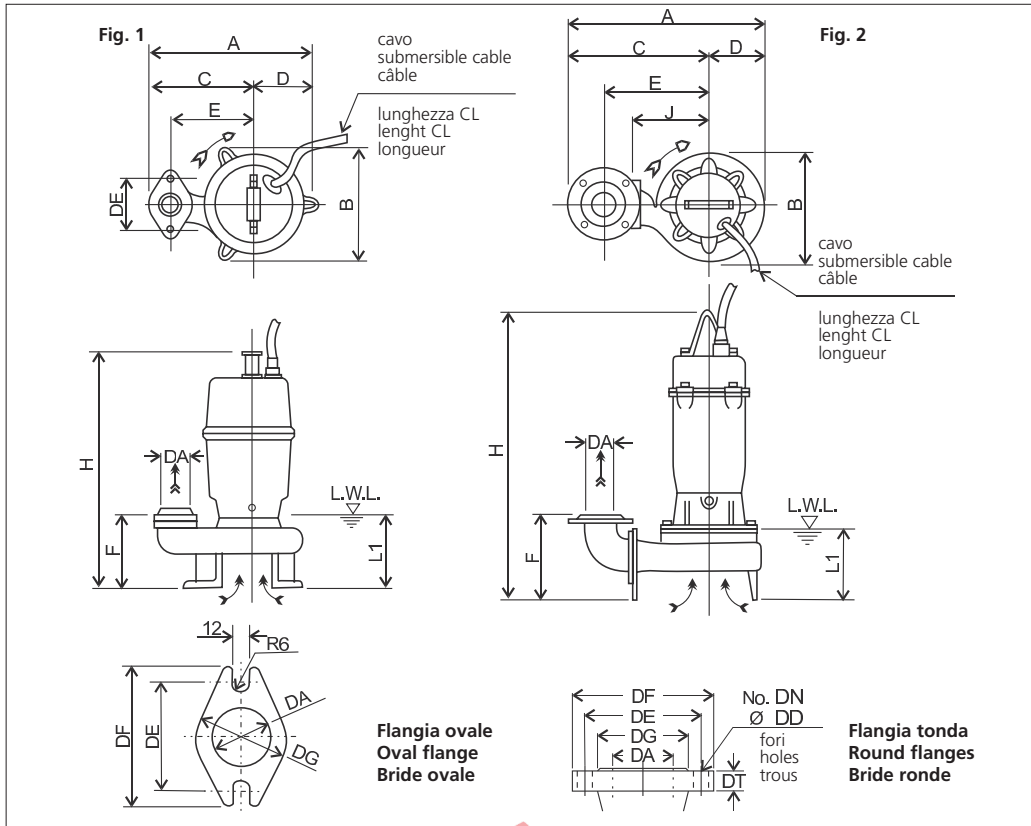

RICAMBI • REPLACEMENT PARTS • PIÈCES DE RECHANGE



TABELLA DIMENSIONI • DIMENSIONS TABLE • TABLEAU DE DIMENSIONS

DA	Modello Model Modèle	Fig.	Tipo Flangia Flanges type Type bride	[kW]	DA	A	B	C	D	E	F	H	DE	J	L1 (*)	CL [m]	Peso Weight Poids [kg]
80	80DVS52.2	2	Tonda • Round • Ronde	1.5	80	411	195	328	98	220	183	519	-	145	125	6	35

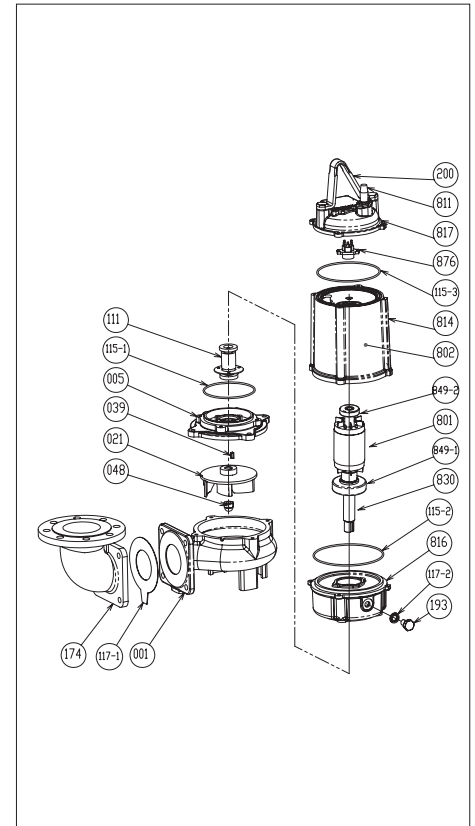
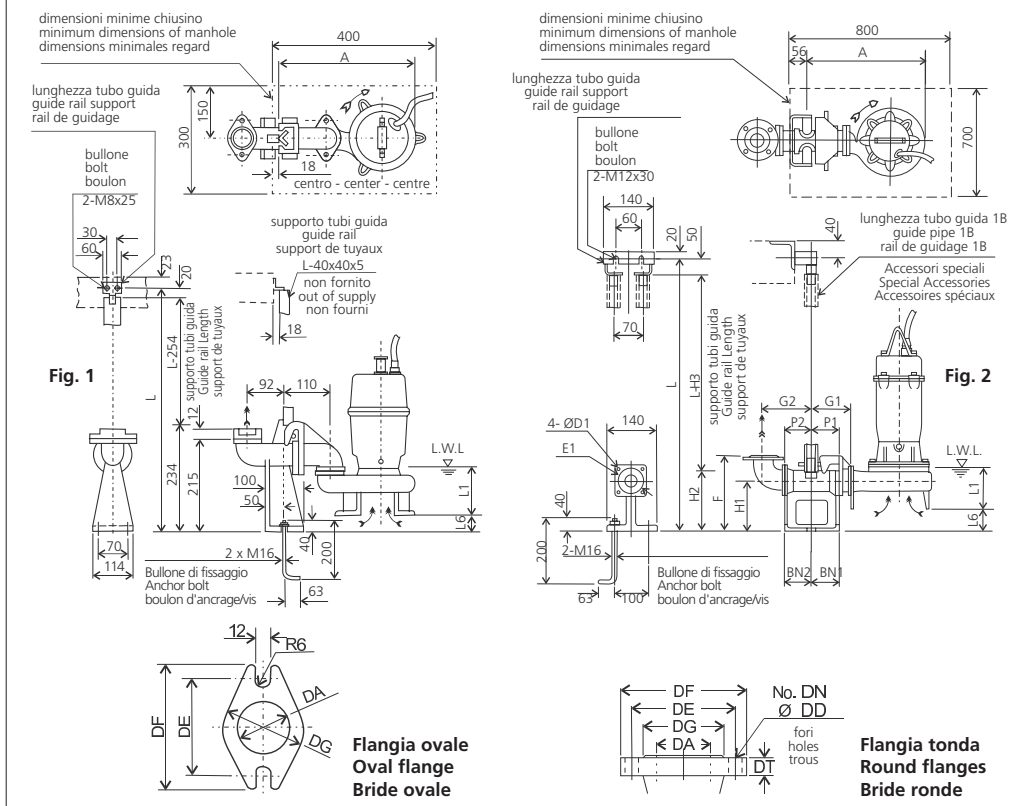

001	Corpo pompa - Pump casing - Corps de la pompe
021	Girante - Impeller - Roue
039	Linguetta - Key - Languette
048	Dado girante - Nut - Écrou roue
111	Tenuta meccanica - Mechanical seal Garniture mécanique
115-2	Anello OR - O-ring - Bague OR
115-3	Anello OR - O-ring - Bague OR
115-1	Anello OR - O-ring - Bague OR
117-1	Guarnizione - Gasket - Joint
117-2	Guarnizione - Gasket - Joint
811	Cavo - Cable - Câble
849-1	Cuscinetto - Bearing - Coussinet
849-2	Cuscinetto - Bearing - Coussinet
876	Termoprotettore - Auto cut - Protection thermique

MODELLO KIT SCIVOLO DISCESA (QDC) QDC MODEL MODÈLE KIT PIED D'ASSISE (QDC) LM65



TABELLA DIMENSIONI QDC • QDC DIMENSIONS TABLE • TABLEAU DE DIMENSIONS QDC

DA	Modello Model Modèle	Fig.	Tipo Flangia Flanges type Type bride	[kW]	A	P1	P2	G1	G2	F	H1	H2	H3	L1 (*)	L6	BN1	BN2	D1	E1	QDC Mod. [kg]	
80	80DVS51.5	2	Tonda • Round • Ronde	1.5	363	75	95	120	170	255	145	190	240	125	72	75	95	12	140	LM65	14

**GIRANTE SEMI-VORTEX
SEMI-VORTEX IMPELLER
ROUE SEMI-VORTEX**

CURVE DI PRESTAZIONE • PERFORMANCE CURVES • COURBES DE PERFORMANCE

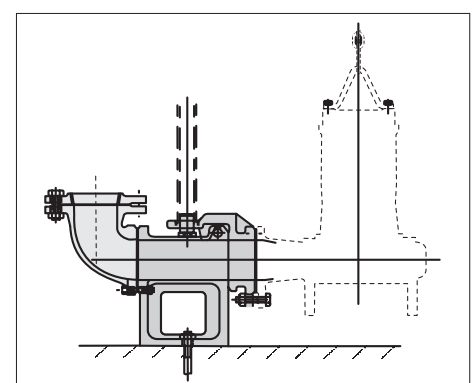

TABELLA PRESTAZIONI • PERFORMANCE TABLE • TABLEAU DE PERFORMANCES

Modello Model Modèle	P ₂		Q = Portata / Flow rate / Débit												
	[HP]	[kW]	l/min 100 m ³ /h 6	150 9	200 12	300 18	400 24	500 30	550 33	600 36	700 42	750 45	900 54	1000 60	
80DVS52.2	3	2.2	-	-	17,5	15,9	14,2	12,3	11,5	10,5	8,1	6,6	-	-	

H = Prevalenza / Head / Hauteur manometrique totale [m]

IDRAULICA • HYDRAULIC • HYDRAULIQUE

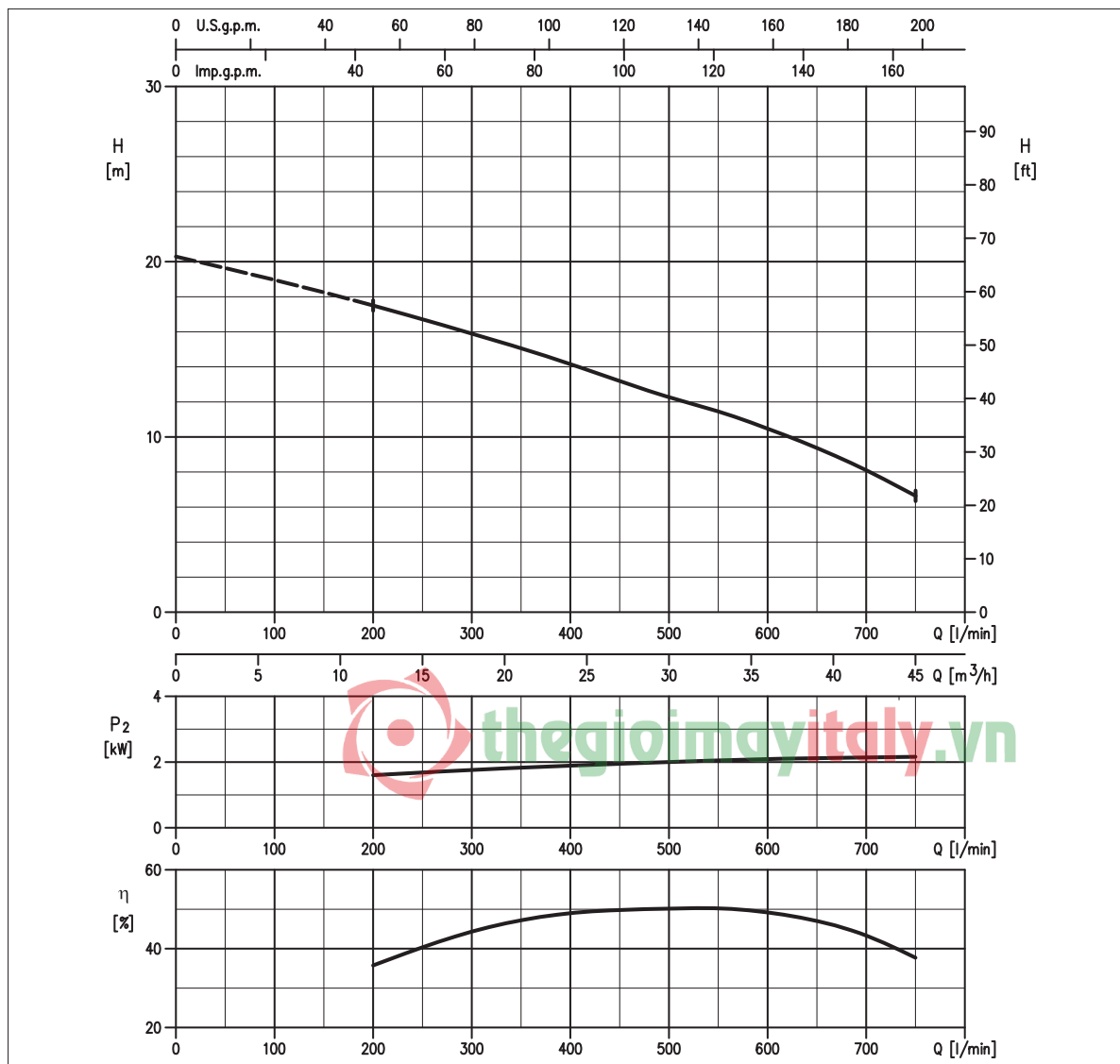
Girante Impeller Roue	SEMI-VORTEX ANTI INTASAMENTO NON-CLOGGED SEMI-VORTEX SEMI-OUVERTE AVEC ANTI COLMATAGE
Mandata Flanges Brides	DN 80 mm
Massimo diametro passaggi liberi Maximum solid diameter Passage libre maximum	41 mm
Temperatura massima del liquido Maximum liquid temperature Température maximale du liquide	40°C
Doppia tenuta meccanica Double mechanical seal Double garniture mécanique	SiC/SiC/NBR Cer/Carb/NBR

TIPO POMPA • PUMP TYPE • TYPE DE POMPE

Peso Weight Poids	51 kg	Costruzione Construction Construction	GHISA CAST IRON FONTE
-------------------------	--------------	---	--------------------------------------

MOTORE • MOTOR • MOTEUR

Tensione Power Tension	380 - 415V ±10%, 50 Hz	Cavo Cable Câble	10 m
Avviamento ora Starts per hour Nombre de démarrages par huere	10	P ₂	2.2 kW
Classe di isolamento Insulation class Classe d'isolation	F	Corrente di avviamento Start Current Ampérage au démarrage	380 V 400 V 415 V 28,7 A 30,0 A 31,5 A
Grado di protezione Protection degree Indice de protection	IP 68	Corrente 100% Current 100% Ampérage 100%	5,10 A 5,00 A 4,60 A
		Velocità di rotazione (rpm) Rotation speed (rpm) Vitesse de rotation (rpm)	2850



DIMENSIONI • DIMENSIONS • DIMENSIONS

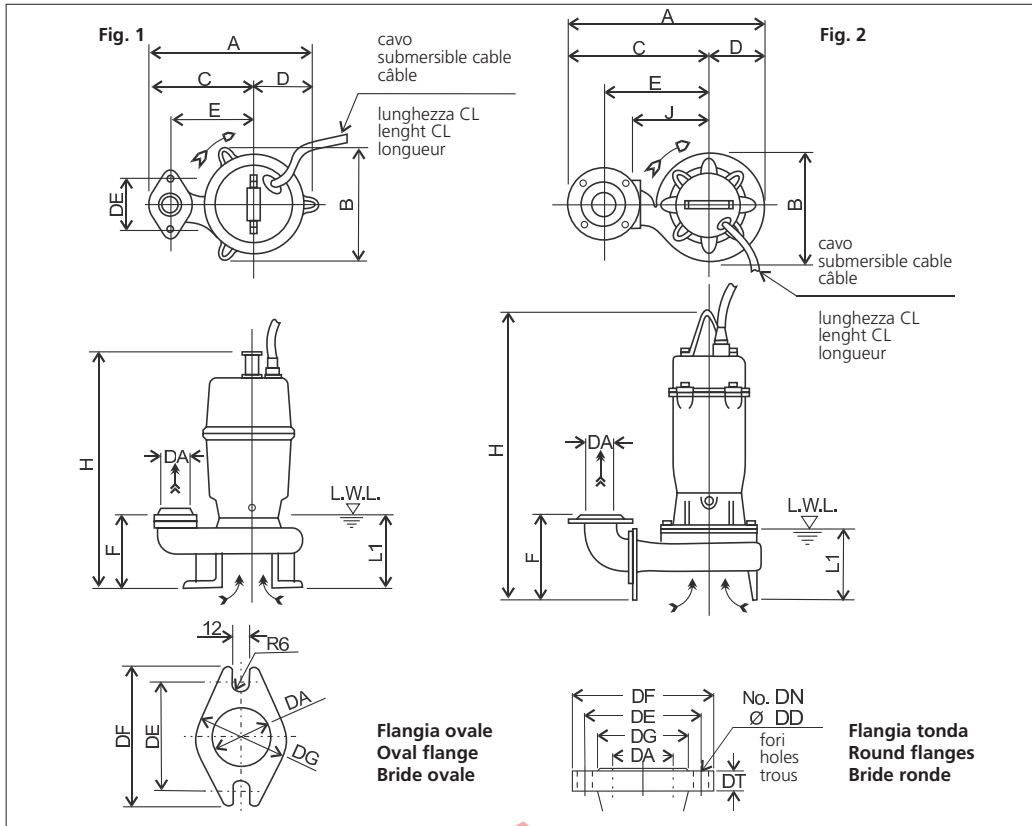

RICAMBI • REPLACEMENT PARTS • PIÈCES DE RECHANGE

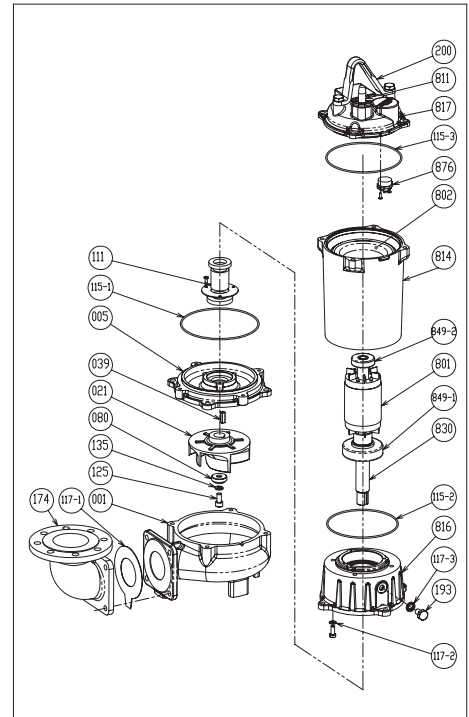

001	Corpo pompa - Pump casing - Corps de la pompe
021	Girante - Impeller - Roue
039	Linguetta - Key - Languette
080	Bussola - Bushing - Bague d'usure
111	Tenuta meccanica - Mechanical seal Garniture mécanique
115-2	Anello OR - O-ring - Bague OR
115-3	Anello OR - O-ring - Bague OR
115-1	Anello OR - O-ring - Bague OR
117-1	Guarnizione - Gasket - Joint
117-2	Guarnizione - Gasket - Joint
117-3	Guarnizione - Gasket - Joint
125	Vite - Screw - Vis
135	Rondella - Washer - Rondelle d'étanchiété
811	Cavo - Cable - Câble
849-1	Cuscinetto - Bearing - Coussinet
849-2	Cuscinetto - Bearing - Coussinet
876	Termoprotettore - Auto cut - Protection thermique

TABELLA DIMENSIONI • DIMENSIONS TABLE • TABLEAU DE DIMENSIONS

DA	Modello Model Modèle	Fig.	Tipo Flangia Flanges type Type bride	[kW]	DA	A	B	C	D	E	F	H	DE	J	L1 (*)	CL [m]	Peso Weight Poids [kg]
80	80DVS52.2	2	Tonda • Round • Ronde	2.2	80	442	227	328	114	235	206	643	-	160	155	10	51

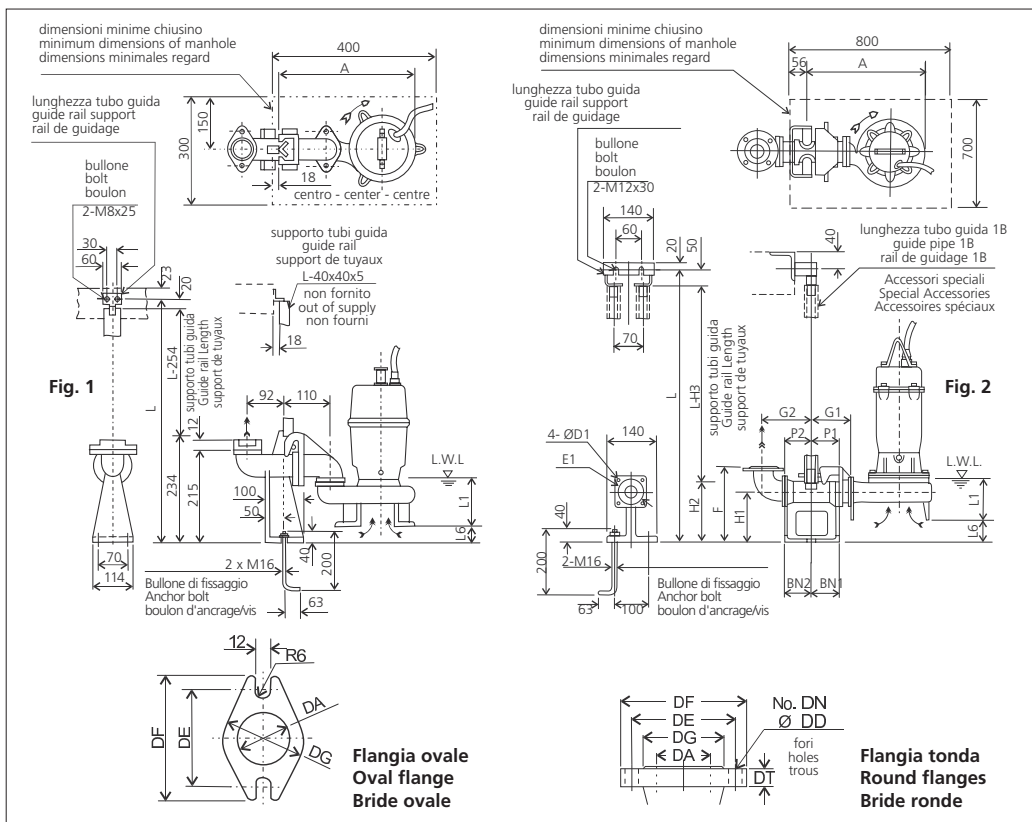

**MODELLO KIT SCIVOLO DISCESA (QDC)
QDC MODEL
MODÈLE KIT PIED D'ASSISE (QDC)
LM65**



TABELLA DIMENSIONI QDC • QDC DIMENSIONS TABLE • TABLEAU DE DIMENSIONS QDC

DA	Modello Model Modèle	Fig.	Tipo Flangia Flanges type Type bride	[kW]	A	P1	P2	G1	G2	F	H1	H2	H3	L1 (*)	L6	BN1	BN2	D1	E1	QDC Mod. [kg]	
80	80DVS52.2	2	Tonda • Round • Ronde	2.2	394	75	95	120	170	255	145	190	240	155	49	75	95	12	140	LM65	14

**GIRANTE SEMI-VORTEX
SEMI-VORTEX IMPELLER
ROUE SEMI-VORTEX**

CURVE DI PRESTAZIONE • PERFORMANCE CURVES • COURBES DE PERFORMANCE

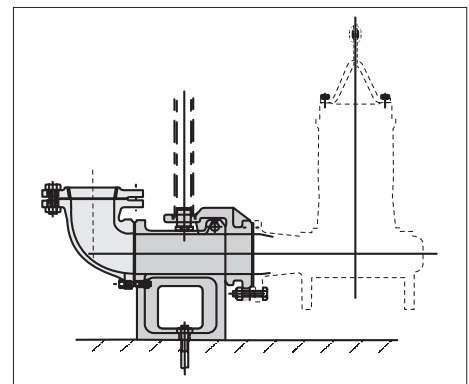

TABELLA PRESTAZIONI • PERFORMANCE TABLE • TABLEAU DE PERFORMANCES

Modello Model Modèle	P ₂		Q = Portata / Flow rate / Débit												
	[HP]	[kW]	l/min 100	150	200	300	400	500	550	600	700	750	900	1000	
			m ³ /h 6	9	12	18	24	30	33	36	42	45	54	60	
80DVS53.7	5	3.7	-	-	23,0	21,6	20,1	18,4	17,6	16,7	15,0	14,0	10,4	6,9	

H = Prevalenza / Head / Hauteur manométrique totale [m]

IDRAULICA • HYDRAULIC • HYDRAULIQUE

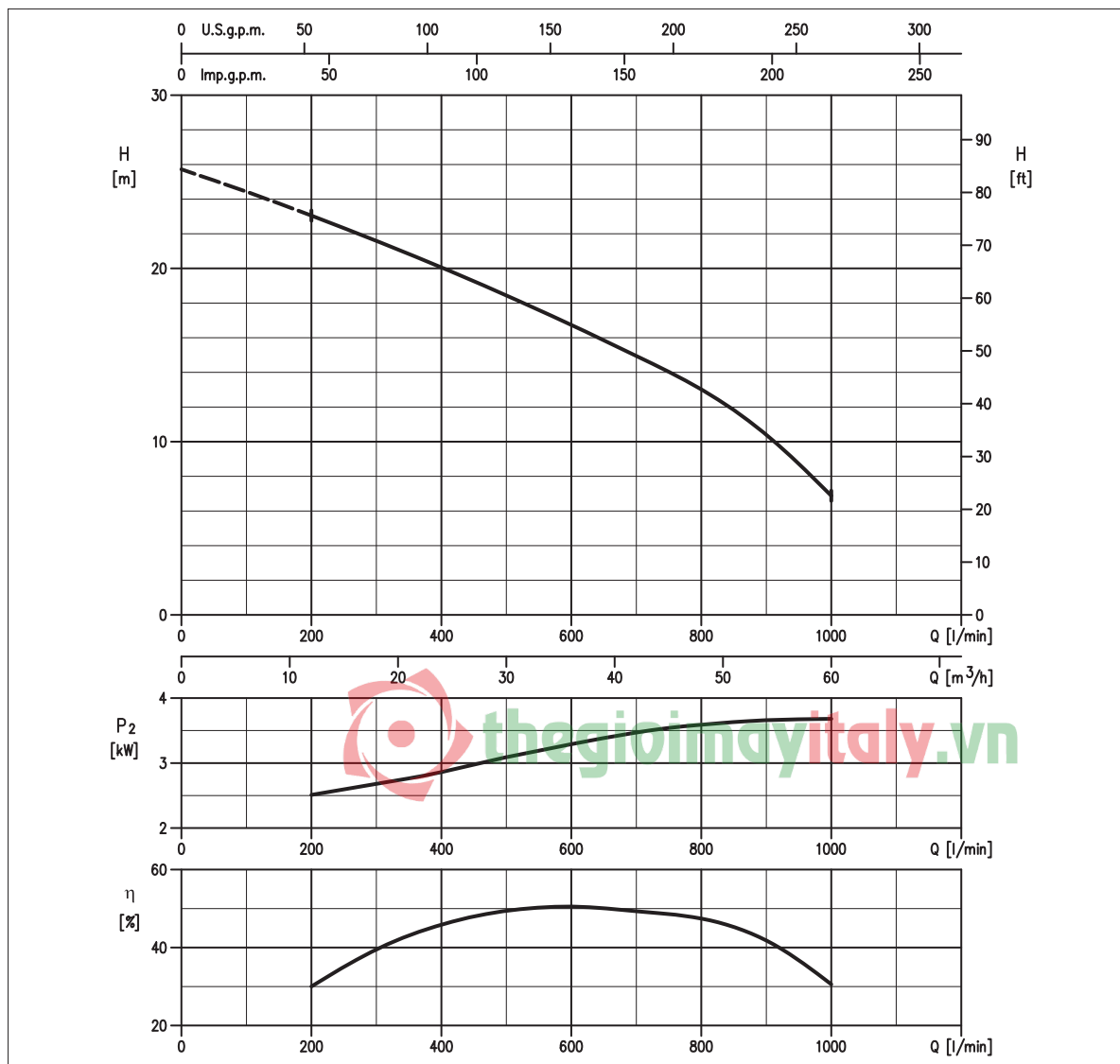
Girante Impeller Roue	SEMI-VORTEX ANTI INTASAMENTO NON-CLOGGED SEMI-VORTEX SEMI-OUVERTE AVEC ANTI COLMATAGE
Mandata Flanges Brides	DN 80 mm
Massimo diametro passaggi liberi Maximum solid diameter Passage libre maximum	41 mm
Temperatura massima del liquido Maximum liquid temperature Température maximale du liquide	40°C
Doppia tenuta meccanica Double mechanical seal Double garniture mécanique	SiC/SiC/NBR Cer/Carb/NBR

TIPO POMPA • PUMP TYPE • TYPE DE POMPE

Peso Weight Poids	60 kg	Costruzione Construction Construction	GHISA CAST IRON FONTE
-------------------------	--------------	---	--------------------------------------

MOTORE • MOTOR • MOTEUR

Tensione Power Tension	380 - 415V ±10%, 50 Hz	Cavo Cable Câble	10 m
Avviamento ora Starts per hour Nombre de démarrages par huere	10	P ₂	3.7 kW
Classe di isolamento Insulation class Classe d'isolation	F	Corrente di avviamento Start Current Ampérage au démarrage	51,2 A 51,0 A 53,0 A
Grado di protezione Protection degree Indice de protection	IP 68	Corrente 100% Current 100% Ampérage 100%	8,80 A 7,80 A 7,80 A
		Velocità di rotazione (rpm) Rotation speed (rpm) Vitesse de rotation (rpm)	2850



DIMENSIONI • DIMENSIONS • DIMENSIONS

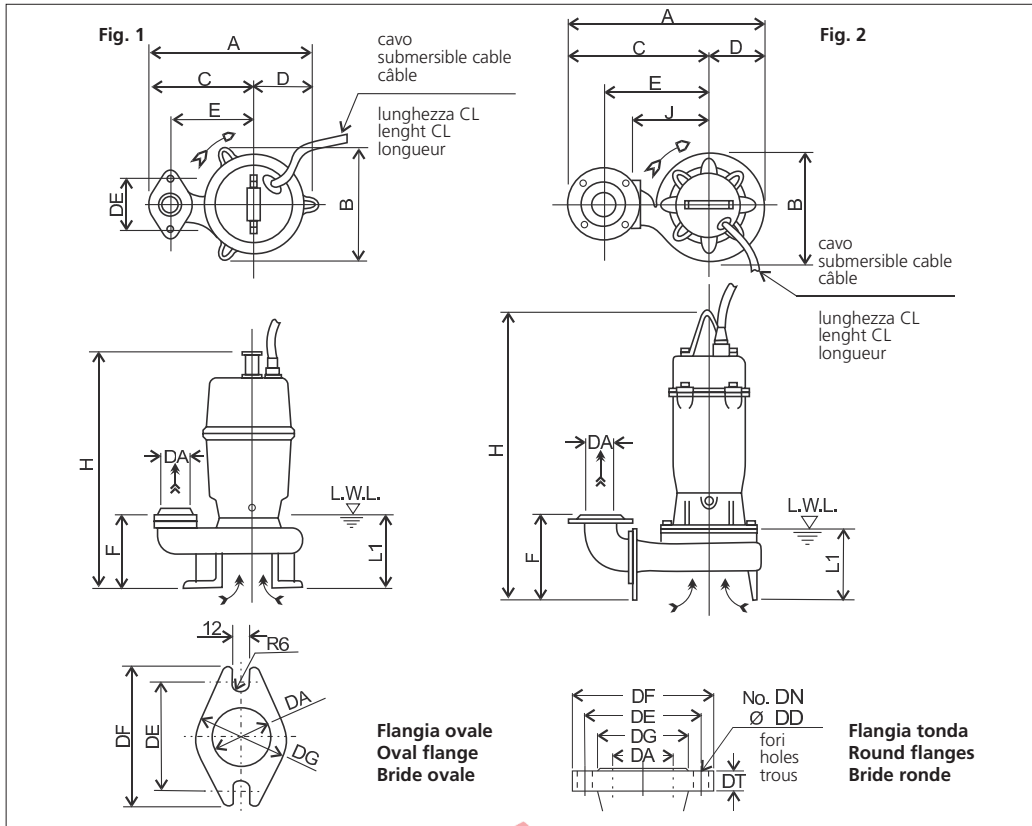

RICAMBI • REPLACEMENT PARTS • PIÈCES DE RECHANGE

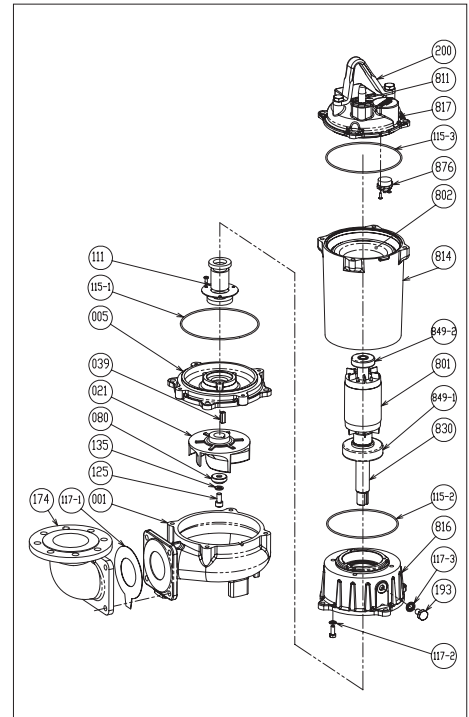

001	Corpo pompa - Pump casing - Corps de la pompe
021	Girante - Impeller - Roue
039	Linguetta - Key - Languette
080	Bussola - Bushing - Bague d'usure
111	Tenuta meccanica - Mechanical seal Garniture mécanique
115-2	Anello OR - O-ring - Bague OR
115-3	Anello OR - O-ring - Bague OR
115-1	Anello OR - O-ring - Bague OR
117-1	Guarnizione - Gasket - Joint
117-2	Guarnizione - Gasket - Joint
117-3	Guarnizione - Gasket - Joint
125	Vite - Screw - Vis
135	Rondella - Washer - Rondelle d'étanchiété
811	Cavo - Cable - Câble
849-1	Cuscinetto - Bearing - Coussinet
849-2	Cuscinetto - Bearing - Coussinet
876	Termoprotettore - Auto cut - Protection thermique

TABELLA DIMENSIONI • DIMENSIONS TABLE • TABLEAU DE DIMENSIONS

DA	Modello Model Modèle	Fig.	Tipo Flangia Flanges type Type bride	[kW]	DA	A	B	C	D	E	F	H	DE	J	L1 (*)	CL [m]	Peso Weight Poids [kg]
80	80DVS53.7	2	Tonda • Round • Ronde	3.7	80	442	227	328	114	235	206	643	-	160	155	10	60

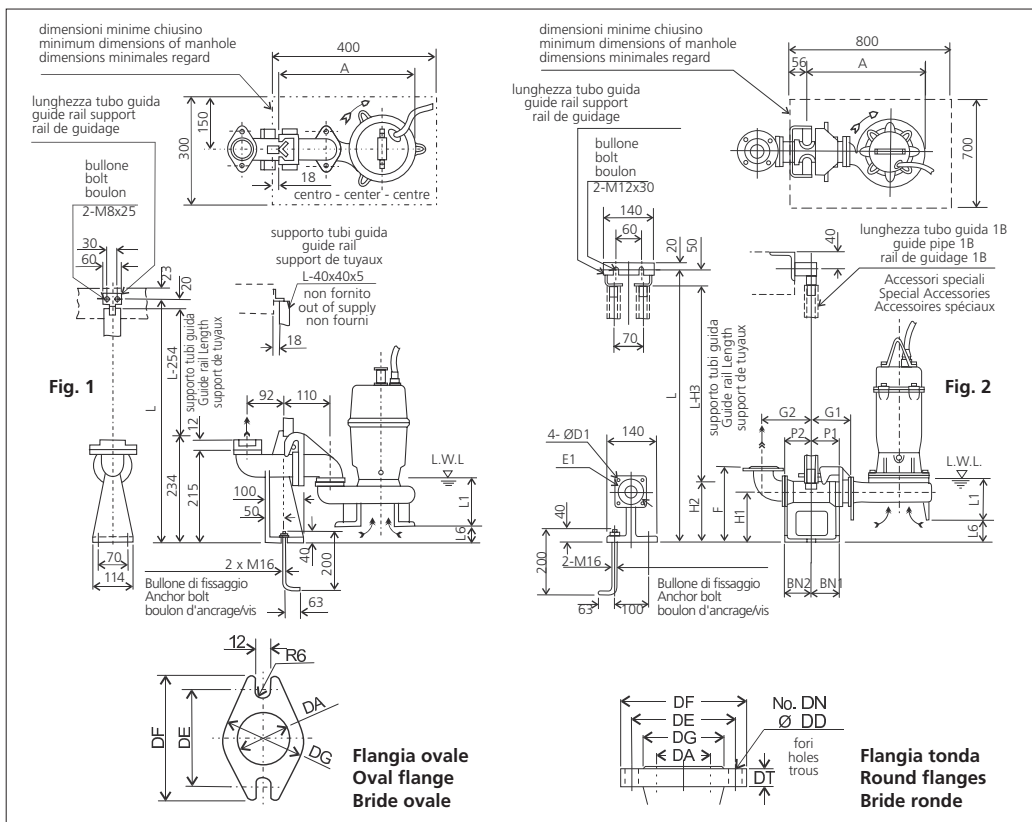

**MODELLO KIT SCIVOLO DISCESA (QDC)
QDC MODEL
MODÈLE KIT PIED D'ASSISE (QDC)
LM65**

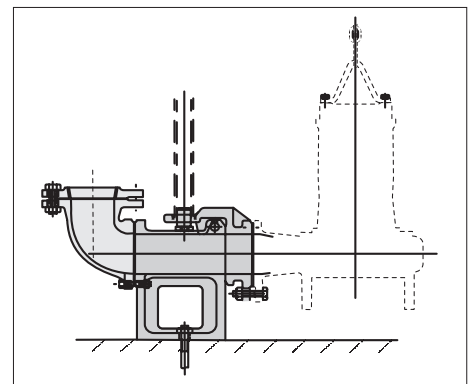

TABELLA DIMENSIONI QDC • QDC DIMENSIONS TABLE • TABLEAU DE DIMENSIONS QDC

DA	Modello Model Modèle	Fig.	Tipo Flangia Flanges type Type bride	[kW]	A	P1	P2	G1	G2	F	H1	H2	H3	L1 (*)	L6	BN1	BN2	D1	E1	QDC Mod. [kg]	
80	80DVS53.7	2	Tonda • Round • Ronde	3.7	394	75	95	120	170	255	145	190	240	155	49	75	95	12	140	LM65	14