

GRUNDFOS®



DATA SHEET

Home
Booster

UPA



UPA 15-90

UPA 120

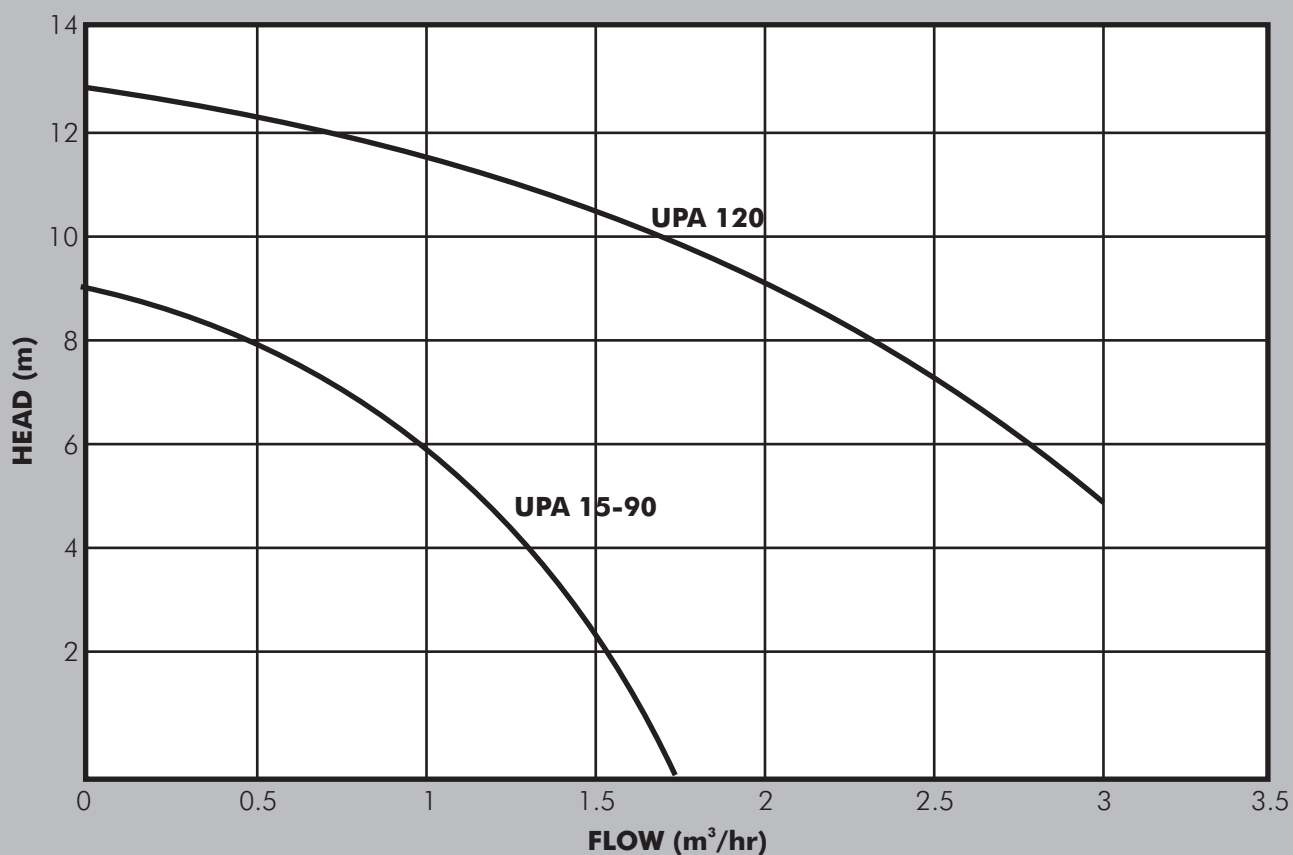

PUMP

The Grundfos UPA mini circulator pumps are designed for pressure boosting of domestic potable and hot water supplies with particular applications for showers, taps and water feeds to appliances. Pumps incorporate a flow switch for automatic on demand operation. They are for use in open systems and the option of manual or auto operation can be selected.

Pump construction is stainless steel encapsulated rotor, rotor can and bearing plate, polycarbonate impeller and cast iron pump housing. Pumps are supplied with a female threaded BSP union connection set.

MOTOR

The integral 2-pole asynchronous squirrel-cage motor includes a built-in thermal switch which monitors winding temperature and cuts off the power supply in the event of overload. No remote overload protection is required, though the pump must be connected to a suitably rated MCB or fuse.

Power Supply: 1x240 V

Enclosure Class: IP42

Insulation Class: UPA15-90-H
UPA 120-F

OPERATING CONDITIONS

Pumped liquid: Thin, clean, chemically non-aggressive liquids without solids, fibres or mineral oils.

Fluid Temperature Range: +2°C to +70°C.

Max. Ambient Temperature: 40°C

Max. Operating Pressure: 6 Bar

Min. Inlet Pressure: 0.2Bar

Max. Relative Humidity: 95%

Installation: Pumps must be installed with the pump shaft horizontal.

ELECTRICAL DATA

Pump	Motor		Weight (kg)
	Power _{P₁} (Watts)	Max. Current (A)	
UPA 15-90	120	0.48	2.5
UPA 120	250	1.14	5

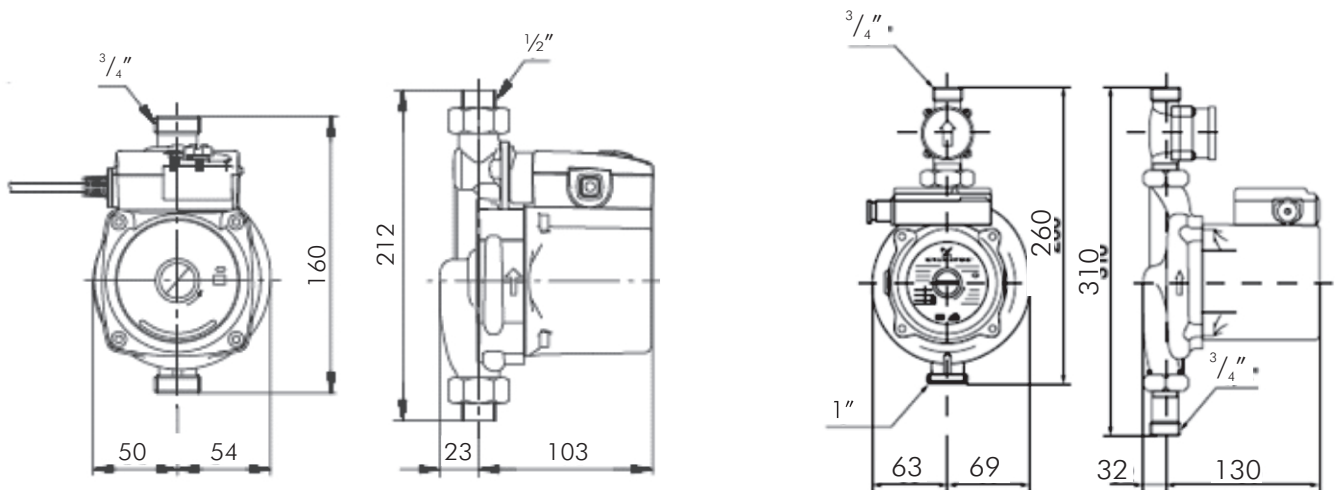

UPA 15-90

UPA 120