



### Application

- Can be used to transfer clean or slightly dirty water or other liquids similar to water in physical and chemical properties
- Suitable to be immersed in water for lifting water from the well or the pool, and draining water from the basement

### Pump

- Engineering plastic pump body
- Float switch ensures automatic cut-in and cut-out
- Max. liquid temperature: +35°C
- Max. immersion depth: 7 m
- Max. diameter of particle: 5 mm

### Motor

- Motor with aluminum winding
- Built-in thermal protector
- Insulation class: F
- Protection class: IPX8

### Identification Codes

#### XKS - 250 P

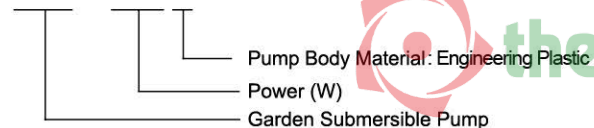

### Hydraulic Performance Curves

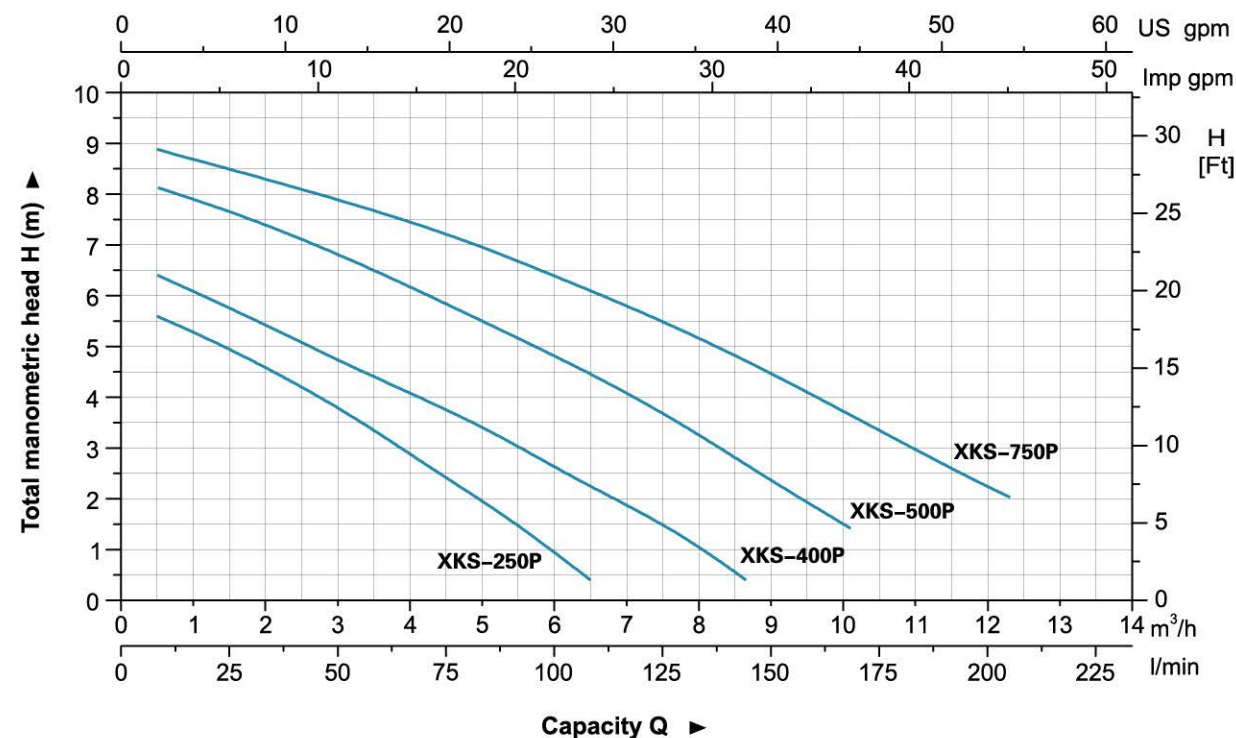

### Materials Table

Pos.	Part	Material
1	Pump base	PP
2	Pump body	PP
3	Capacitor	
4	Cable	
5	Roof	PP
6	Float switch	
7	Upper cover	
8	Stator	
9	Bearing	
10	Rotor	
11	Lip seal	
12	Bearing seat	DMC
13	O-ring	NBR
14	Stator shield	Steel
15	O-ring	NBR
16	Lip seal	
17	Impeller	PA6
18	Nut	AISI 304

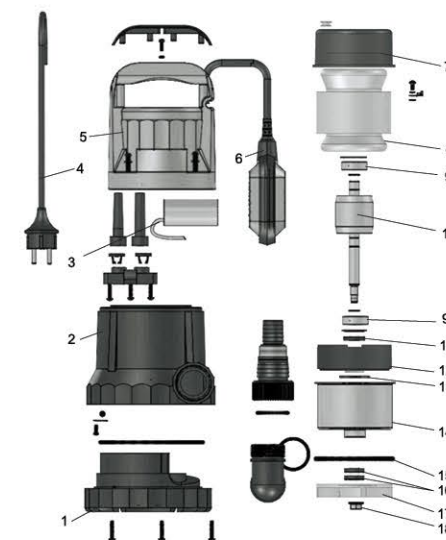

### Technical Data

MODEL	POWER		Q (m³/h) Q (l/min)	H (m)							
	W	HP		0	1.5	3	4.5	6	7.5	9	10.5
XKS-250P	250	0.3	0	5.8	5	3.8	2.4	-	-	-	-
XKS-400P	400	0.5	0	6.5	5.8	4.7	3.7	2.6	1.5	-	-
XKS-500P	500	0.7	0	7.6	7.6	6.8	5.7	4.7	3.6	2.3	-
XKS-750P	750	1	0	8.7	8.5	7.7	7.2	6.2	5.5	4.5	3.2

### Dimension

Model	DN	L (mm)	W (mm)	H (mm)
XKS-250P	32	213	158	300.5
XKS-400P		213	158	300.5
XKS-500P		213	158	300.5
XKS-750P	40	213	158	317.5

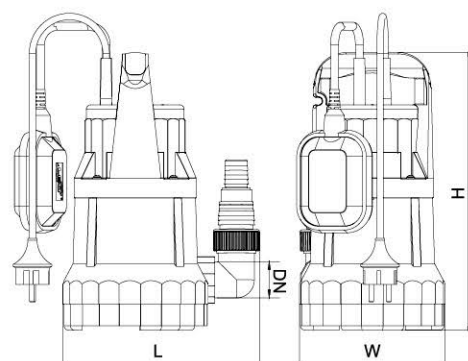

### Package Information

Model	GW (Kgs)	L (mm)	W (mm)	H (mm)	Quantity (PCS/20' TEU)
XKS-250P	4.8	210	160	340	2064
XKS-400P	5.1	210	160	330	2064
XKS-500P	5.5	210	160	340	2064
XKS-750P	6.0	210	160	340	2064

