

6" 6L line



CARATTERISTICHE COSTRUTTIVE / CONSTRUCTION FEATURES CARACTERÍSTICAS CONSTRUCTIVAS / CARACTÉRISTIQUES D'EXÉCUTION	
Corpo d'Aspirazione e di Mandata Suction and delivery outlet	AISI 304 Microfuso AISI 304 Micro-casted
Caja de Aspiracion y de Impulsión Cage d'aspiration et de refoulement	AISI 304 Microfundido AISI 304 Micro-moulé
Valvola Body Valvula Plat	AISI 304
Giranti e diffusori Impellers and diffusers Rodetes y difusores Turbines et diffuseurs	policarbonato alimentare Lexan foodstuff polycarbonate Lexan policarbonato alimentario Lexan polycarbonate alimentaire Lexan
Bronzina superiore Upper bushings Cojinete superior Coussinet de bague supérieur	gomma NBR NBR rubber goma NBR caoutchouc NBR
Albero corpo pompa Shaft pump side Eje cuerpo bomba Arbre pompe	AISI 420
Quantità di sabbia nell'acqua Quantity of sand in the water Cantidad de arena en el agua Quantité de sable dans l'eau	max 400 gr/m ³
MOTORE / MOTOR / MOTOR / MOTEUR	
Asincrono 2 poli Asynchronous 2 pole Asíncrono 2 polos Asínchrone 2 pôles	incapsulato non riavvolgibile o riavvolgibile in bagno d'olio encapsulated not rewindable or rewindable in oil bath encapsulado no bobinable o bobinable en baño de aceite encapsulé non re-enroulable enroulable en bain d'huile
Classe di isolamento Insulation class Clase de aislamiento Classe d'isolation	F
Grado di protezione Protection degree Grado de protección protection	IP68
Temperatura del liquido Liquid temperature Temperatura del líquido Température du liquide	max 30 °C

Pompe sommerse centrifughe multistadio per pozzi da 6". Valvola di ritegno incorporata nella bocca di mandata. Flangia di accoppiamento al motore secondo la normativa NEMA. Applicazioni civili e agricole sono tra le più comuni.

Submersible multistage centrifugal pumps for 6" wells. Check valve built into the delivery outlet. Pump flange for coupling with motors are made according to NEMA standards. Most common applications are civil and agricultural.

Bombas sumergibles para pozos de 6". Válvula de retención incorporada en la boca de impulsión. Brida de conexión al motor según norma NEMA. Utilizadas en particular para aplicaciones civiles y agrícolas.

Pompes immergées centrifuges multietagées pour puits de 6". Clapet de retenue incorporé dans l'orifice de refoulement. Bride d'accouplement au moteur est exécutée selon normes NEMA. Les applications civiles et agricoles sont parmi les plus communes.

6" 6L 8

Motor 50 Hz - 2900 rpm				Q								
TYPE	Power		400 V	I/min	0	60	80	100	120	140	160	180
	(HP)	(kW)		I/sec	0	1	1,33	1,67	2	2,33	2,67	3
	A	A	m ³ /h	0	3,6	4,8	6	7,2	8,4	9,6	10,8	
6L 8/05	3	2,20	5,5	H[m]	73	68	64	57	48	39	30	15
6L 8/07	4	3	6,7		102	95	90	79	67	54	42	21
6L 8/10	5,5	4	10		146	136	128	113	96	77	60	30
6L 8/14	7,5	5,50	12,5		204	190	179	158	134	108	84	42
6L 8/19	10	7,50	17,5		277	258	243	215	182	146	114	57
6L 8/23	12,5	9,20	21		336	313	294	260	221	177	138	69
6L 8/28	15	11	24,5		409	381	358	316	269	216	168	84
6L 8/33	17,5	13	28		482	449	422	373	317	254	198	99

Motor 50 Hz 2900 rpm	Dimensions (mm)			Weight (kg)	
TYPE	A	B	C	M	P
6L 8/05	947	495	452	15	14
6L 8/07	1104	547	557	19	16
6L 8/10	1222	625	597	22	18
6L 8/14	1427	729	698	27	21
6L 8/19	1592	891	701	55	25
6L 8/23	1746	995	751	60	28
6L 8/28	1936	1125	811	65	32
6L 8/33	2096	1255	841	70	36

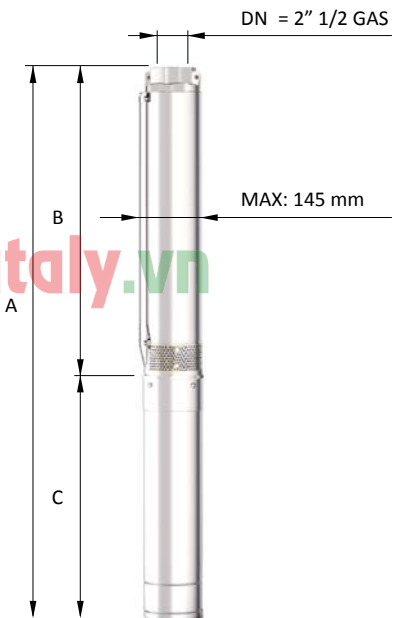

MEI ≥ 0,4 (direttiva EU No. 547/2012 - regulation EU N. 547/2012)

Tolleranze secondo UNI ISO 9906 livello 3B - Tolerances according to UNI ISO 9906 grade 3B

6" 6L 8

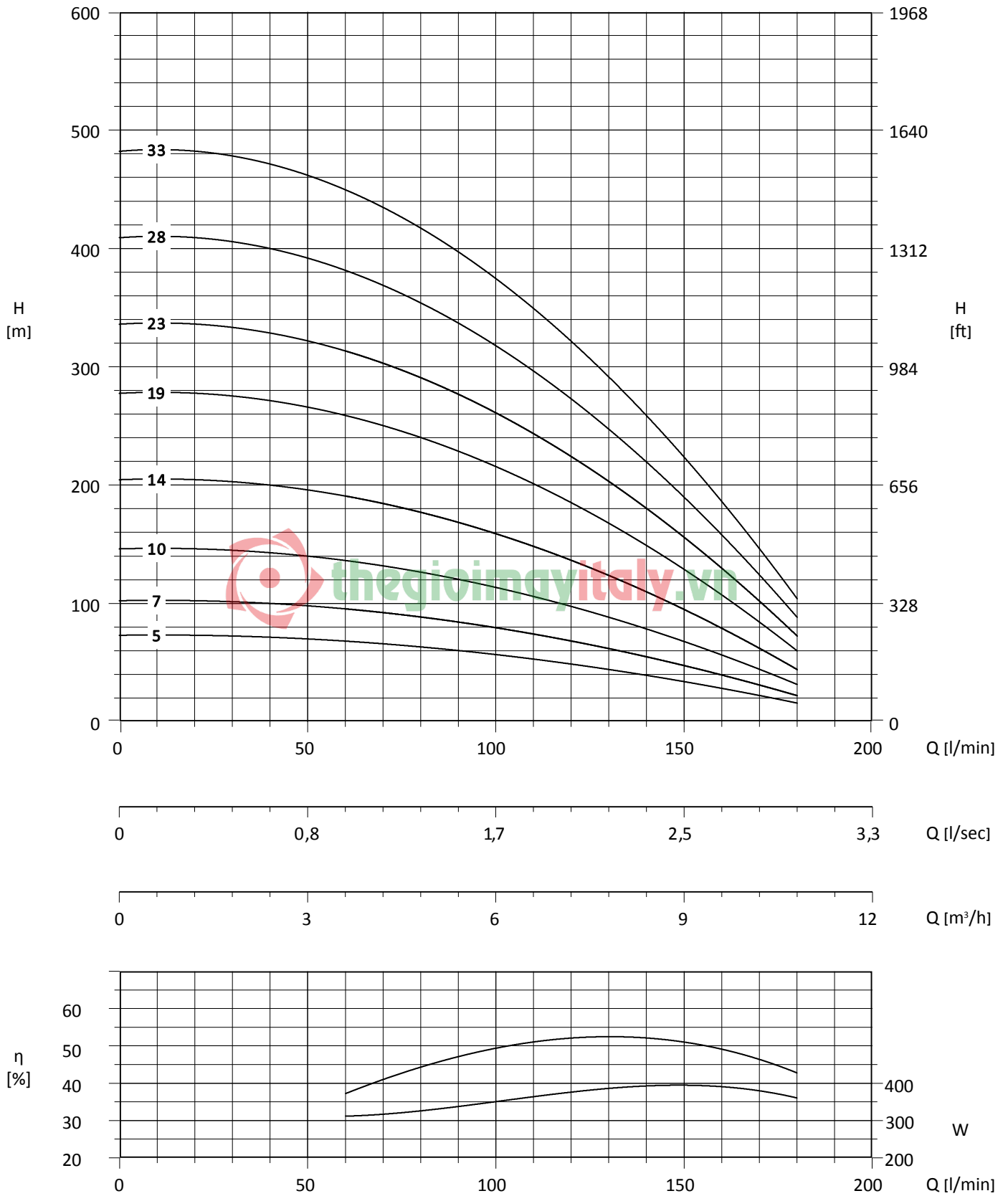

MEI ≥ 0,4 (direttiva EU No. 547/2012 - regulation EU N. 547/2012)

Tolleranze secondo UNI ISO 9906 livello 3B - Tolerances according to UNI ISO 9906 grade 3B

6" 6L 9

Motor 50 Hz - 2900 rpm				Q									
TYPE	Power		400 V	I/min	0	80	100	120	140	160	180	200	220
	(HP)	(kW)		I/sec	0	1,33	1,67	2,00	2,33	2,67	3,00	3,33	3,67
	A	m ³ /h	0	4,8	6	7,2	8,4	9,6	10,8	12,0	13,2		
6L 9/05	3	2,20	5,5	H[m]	75	68	64	58	52	44	36	27	18
6L 9/07	4	3	6,7		105	95	90	81	72	62	50	37	25
6L 9/10	5,5	4	10		150	136	128	116	103	88	71	53	35
6L 9/13	7,5	5,50	12,5		195	177	166	151	134	114	92	69	49
6L 9/18	10	7,50	17,5		270	245	230	209	185	158	128	95	63
6L 9/22	12,5	9,20	21		330	299	282	255	227	194	156	117	77
6L 9/27	15	11	24,5		405	367	346	313	278	238	192	143	95
6L 9/32	17,5	13	28		480	435	410	371	330	282	227	170	112
6L 9/36	20	15	32		540	490	461	418	371	317	256	191	126

Motor 50 Hz - 2900 rpm	Dimensions (mm)			Weight (kg)	
TYPE	A	B	C	M	P
6L 9/05	947	495	452	15	14
6L 9/07	1104	547	557	19	16
6L 9/10	1222	625	597	22	18
6L 9/13	1401	703	698	27	21
6L 9/18	1651	833	818	32	25
6L 9/22	1720	969	751	60	28
6L 9/27	1910	1099	811	65	32
6L 9/32	2070	1229	841	70	36
6L 9/36	2264	1333	931	75	40

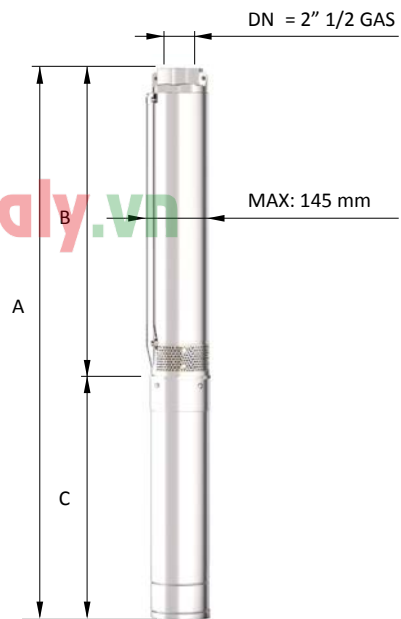

MEI ≥ 0,4 (direttiva EU No. 547/2012 - regulation EU N. 547/2012)

Tolleranze secondo UNI ISO 9906 livello 3B - Tolerances according to UNI ISO 9906 grade 3B

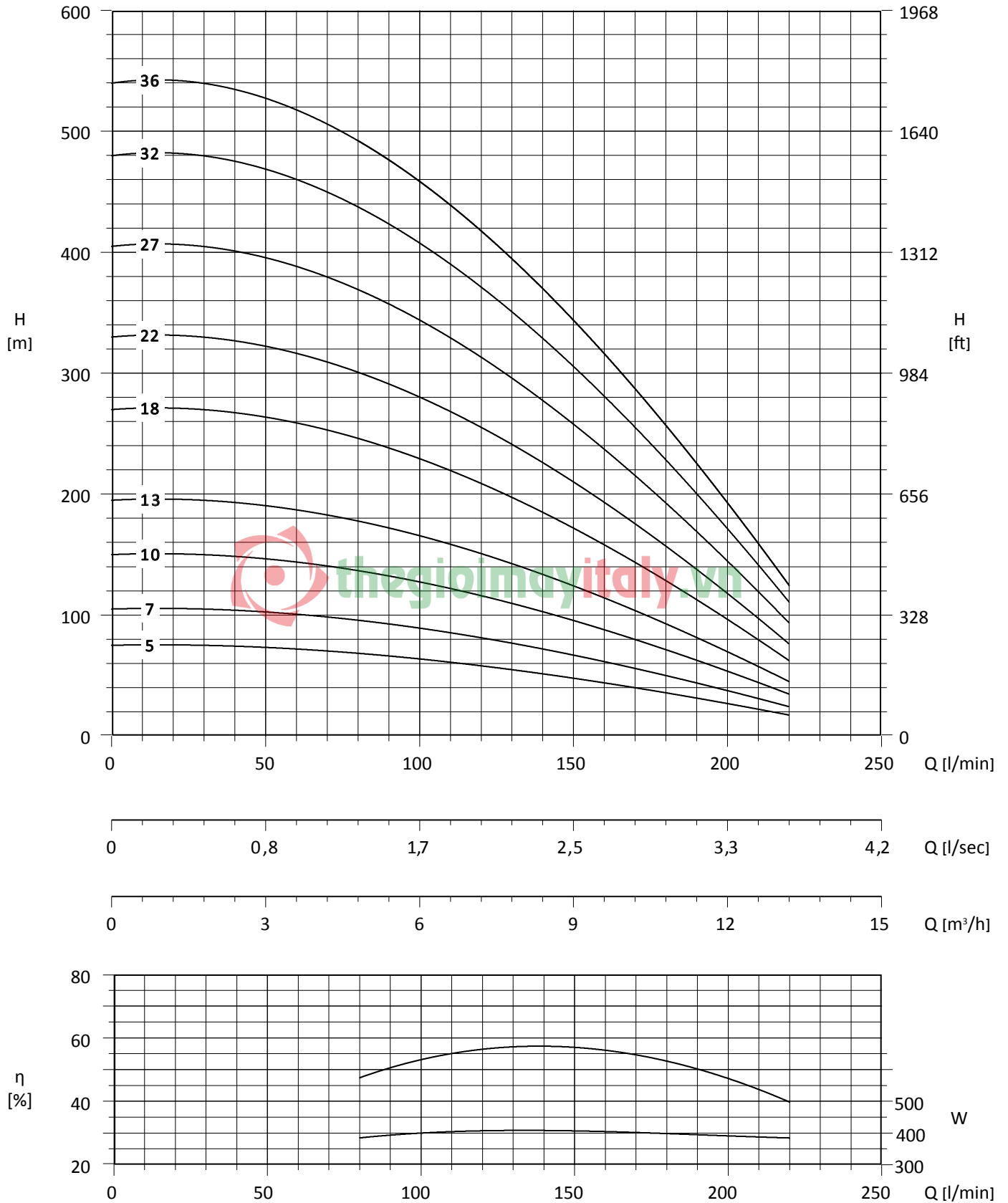

MEI $\geq 0,4$ (direttiva EU No. 547/2012 - regulation EU N. 547/2012)

Tolleranze secondo UNI ISO 9906 livello 3B - Tolerances according to UNI ISO 9906 grade 3B

6" 6L 12

Motor 50 Hz - 2900 rpm				Q								
TYPE	Power		400 V	I/min	0	80	110	140	170	200	230	260
	(HP)	(kW)		I/sec	0	1,33	1,83	2,33	2,83	3,33	3,83	4,33
	A		m ³ /h	0	4,8	6,6	8,4	10,2	12	13,8	15,6	
6L 12/04	3	2,20	5,5	H[m]	64	62	59	56	51	45	37	26
6L 12/06	4	3	6,7		96	93	89	84	77	68	56	39
6L 12/08	5,5	4	10		128	124	118	112	102	90	74	52
6L 12/11	7,5	5,50	12,5		176	171	162	154	140	124	102	72
6L 12/15	10	7,50	17,5		240	233	221	210	191	169	139	98
6L 12/18	12,5	9,20	21		288	279	266	252	230	203	167	117
6L 12/22	15	11	24,5		352	341	325	308	281	248	204	143
6L 12/26	17,5	13	28		416	403	384	364	332	293	241	169
6L 12/30	20	15	32		480	465	443	420	383	338	278	195

Motor 50 Hz - 2900 rpm	Dimensions (mm)			Weight (kg)	
TYPE	A	B	C	M	P
6L 12/04	921	469	452	15	14
6L 12/06	1078	521	557	19	16
6L 12/08	1170	573	597	22	18
6L 12/11	1349	651	698	27	21
6L 12/15	1456	755	701	55	25
6L 12/18	1584	833	751	60	28
6L 12/22	1780	969	811	65	32
6L 12/26	1914	1073	841	70	36
6L 12/30	2108	1177	931	75	40

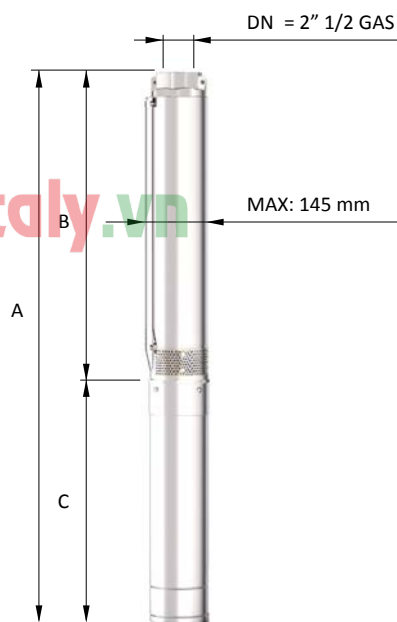

MEI ≥ 0,4 (direttiva EU No. 547/2012 - regulation EU N. 547/2012)

Tolleranze secondo UNI ISO 9906 livello 3B - Tolerances according to UNI ISO 9906 grade 3B

6" 6L 12

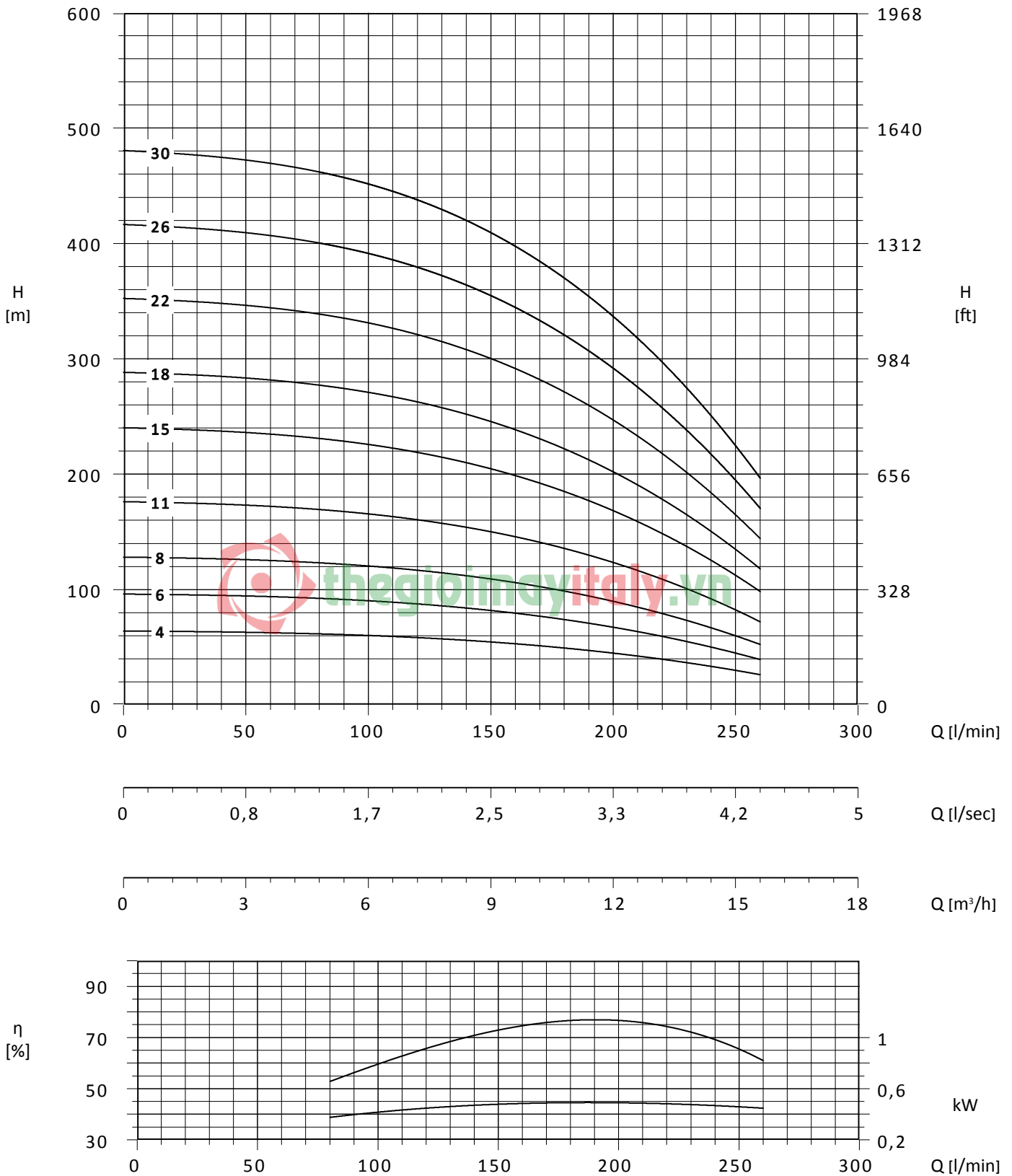

MEI ≥ 0,4 (direttiva EU No. 547/2012 - regulation EU N. 547/2012)

Tolleranze secondo UNI ISO 9906 livello 3B - Tolerances according to UNI ISO 9906 grade 3B

6" 6L 14

Motor 50 Hz - 2900 rpm				Q						
TYPE	Power		400 V	l/min	0	100	150	200	250	300
	(HP)	(kW)	A	l/sec	0	1,67	2,50	3,33	4,17	5
				m ³ /h	0	6	9	12	15	18
6L 14/06	4	3	6,7	H[m]	82	78	74	66	54	38
6L 14/08	5,5	4,00	10		109	104	99	88	72	51
6L 14/11	7,5	5,50	12,5		150	143	136	121	99	70
6L 14/14	10	7,50	17,5		191	182	173	154	126	89
6L 14/18	12,5	9,20	21		246	234	222	198	162	114
6L 14/20	15	11	24,5		273	260	247	220	180	127
6L 14/25	17,5	13	28		342	325	308	275	225	158
6L 14/30	20	15	32		410	390	370	330	270	190
6L 14/35	25	18,50	40		478	455	432	385	315	222
6L 14/40	30	22	47,5		546	520	493	440	360	253

Motor 50 Hz 2900 rpm	Dimensions (mm)			Weight (kg)	
TYPE	A	B	C	M	P
6L 14/06	1078	521	557	19	16
6L 14/08	1170	573	597	22	18
6L 14/11	1349	651	698	27	21
6L 14/14	1430	729	701	55	25
6L 14/18	1616	865	751	60	29
6L 14/20	1728	917	811	65	31
6L 14/25	1888	1047	841	70	37
6L 14/30	2108	1177	931	75	42
6L 14/35	2330	1339	991	83	47
6L 14/40	2540	1469	1071	92	52

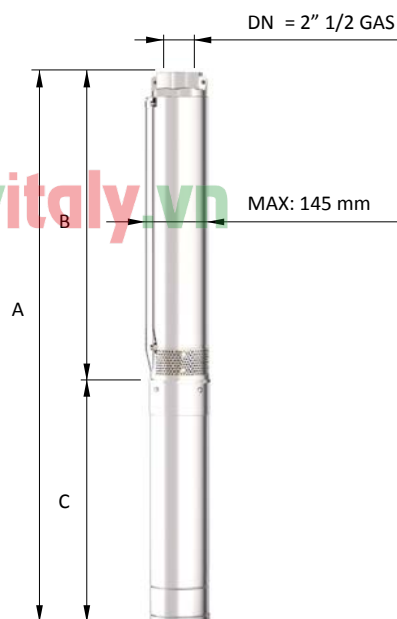

MEI $\geq 0,4$ (direttiva EU No. 547/2012 - regulation EU N. 547/2012)

Tolleranze secondo UNI ISO 9906 livello 3B - Tolerances according to UNI ISO 9906 grade 3B

6" 6L 14

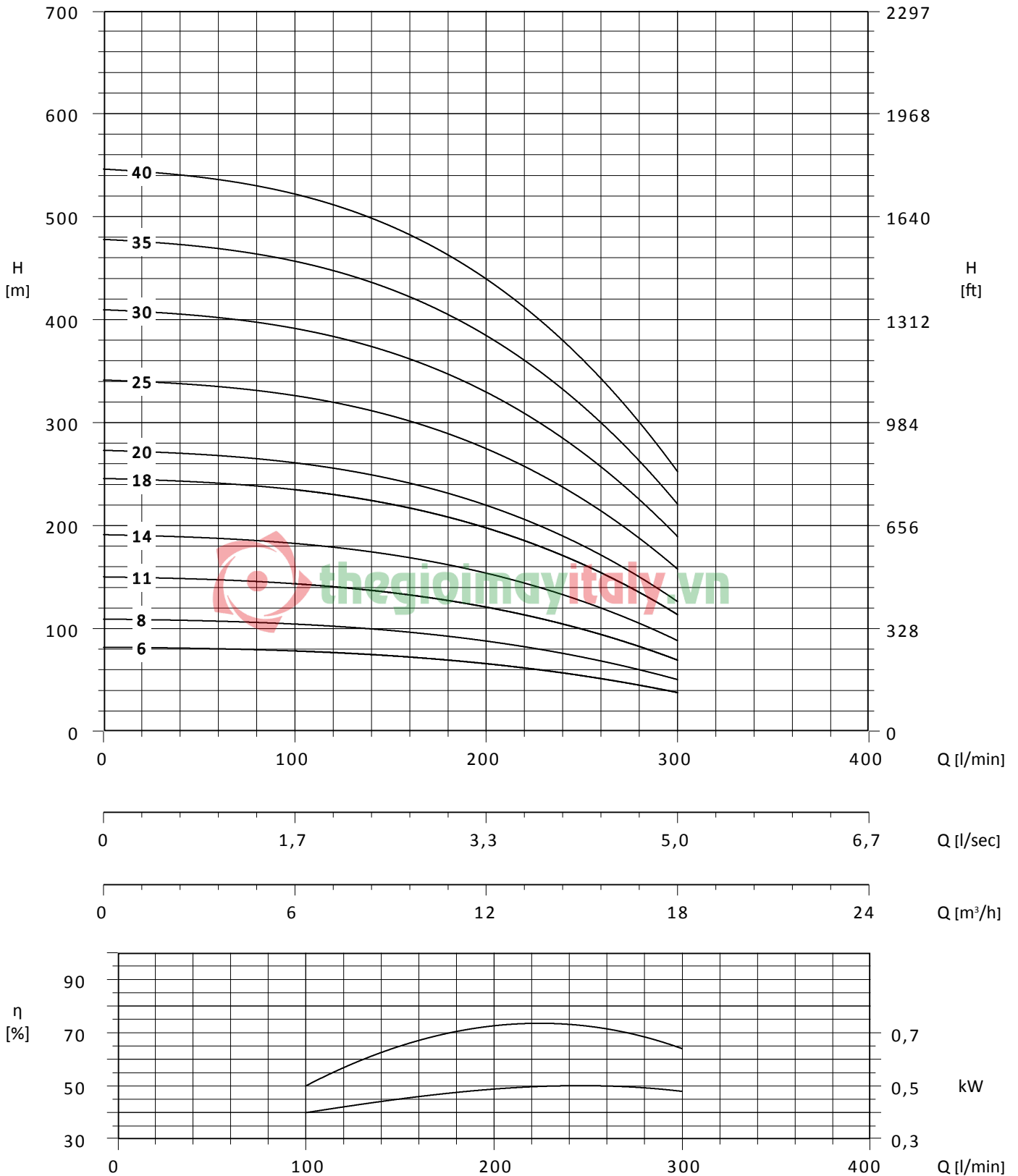

MEI ≥ 0,4 (direttiva EU No. 547/2012 - regulation EU N. 547/2012)
 Tolleranze secondo UNI ISO 9906 livello 3B - Tolerances according to UNI ISO 9906 grade 3B

6" 6L 17

Motor 50 Hz - 2900 rpm				Q								
TYPE	Power		400 V	l/min	0	150	200	250	300	350	400	450
	(HP)	(kW)	A	l/sec	0	2,50	3,33	4,17	5	5,83	6,67	7,50
				m ³ /h	0	9	12	15	18	21	24	27
6L 17/03	4	3	6,7	H[m]	51	47	44	42	36	30	23	14
6L 17/05	5,5	4	10		84	78	74	69	60	50	38	23
6L 17/06	7,5	5,50	12,5		101	93	89	83	72	60	45	28
6L 17/09	10	7,50	17,5		152	140	133	125	108	89	68	41
6L 17/11	12,5	9,20	21		185	171	162	152	132	109	83	51
6L 17/13	15	11	24,5		219	202	192	180	156	129	98	60
6L 17/15	17,5	13	28		253	234	221	208	180	149	113	69
6L 17/18	20	15	32		303	280	266	249	217	179	135	83
6L 17/22	25	18,50	40		370	343	325	304	265	218	165	101
6L 17/26	30	22	47,5		438	405	384	360	313	258	195	120
6L 17/31	35	26	55		522	483	458	429	373	308	233	143
6L 17/36	40	30	62,5		606	561	531	498	433	357	270	166

Motor 50 Hz - 2900 rpm	Dimensions (mm)			Weight (kg)	
TYPE	A	B	C	M	P
6L 17/03	1022,5	465,5	557	19	14
6L 17/05	1129,5	532,5	597	22	15
6L 17/06	1264	566	698	27	16
6L 17/09	1484,5	666,5	818	32	18
6L 17/11	1484,5	733,5	751	60	22
6L 17/13	1611,5	800,5	811	65	24
6L 17/15	1708,5	867,5	841	70	27
6L 17/18	1899	968	931	75	31
6L 17/22	2093	1102	991	83	34
6L 17/26	2307	1236	1071	92	38
6L 17/31	2584,5	1403,5	1181	100	40
6L 17/36	2822	1571	1251	108	42

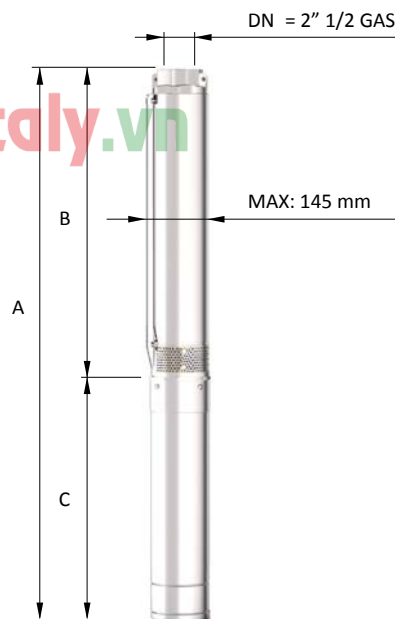

MEI ≥ 0,4 (direttiva EU No. 547/2012 - regulation EU N. 547/2012)

Tolleranze secondo UNI ISO 9906 livello 3B - Tolerances according to UNI ISO 9906 grade 3B

6" 6L 17

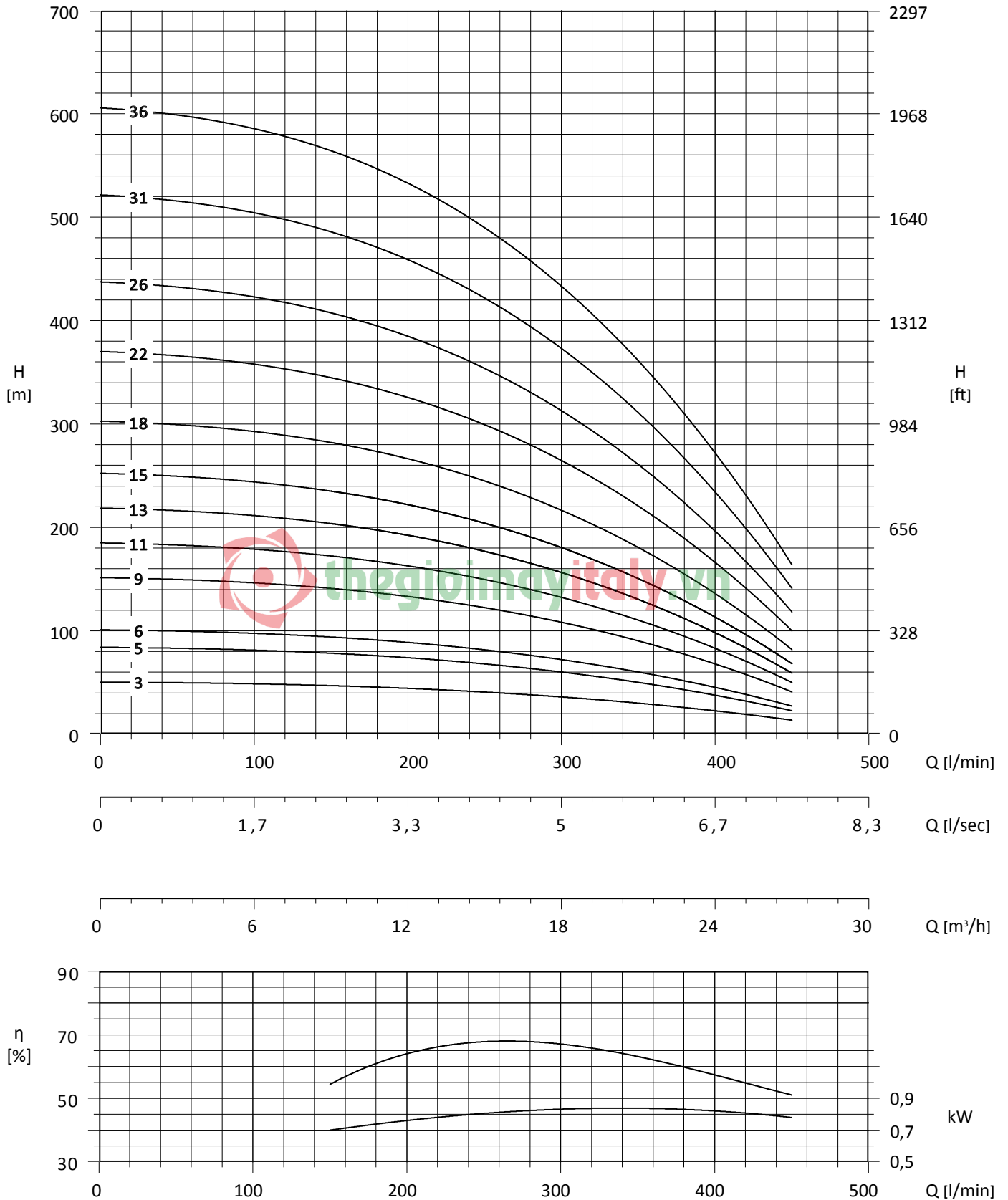

MEI $\geq 0,4$ (direttiva EU No. 547/2012 - regulation EU N. 547/2012)

Tolleranze secondo UNI ISO 9906 livello 3B - Tolerances according to UNI ISO 9906 grade 3B

6" 6L 23

Motor 50 Hz - 2900 rpm				Q						
TYPE	Power		400 V	l/min	0	200	300	400	500	600
	(HP)	(kW)	A	l/sec	0	3,33	5	6,67	8,33	10
				m ³ /h	0	12	18	24	30	36
6L 23/04	4	3	6,7	H[m]	54	47	43	35	24	11
6L 23/05	5,5	4	10		68	59	54	44	30	14
6L 23/07	7,5	5,50	12,5		95	82	75	61	41	20
6L 23/09	10	7,50	17,5		122	105	96	78	53	26
6L 23/11	12,5	9,20	21		149	129	118	96	65	31
6L 23/13	15	11	24,5		176	152	139	113	77	37
6L 23/16	17,5	13	28		217	187	171	139	95	46
6L 23/18	20	15	32		244	211	193	157	107	51
6L 23/22	25	18,50	40		299	257	236	192	130	63
6L 23/26	30	22	47,5		353	304	278	226	154	74
6L 23/31	35	26	55		421	363	332	270	184	88
6L 23/36	40	30	62,5		489	421	386	314	213	103

Motor 50 Hz 2900 rpm	Dimensions (mm)			Weight (kg)	
TYPE	A	B	C	M	P
6L 23/04	1102	545	557	19	14
6L 23/05	1187	590	597	22	16
6L 23/07	1378	680	698	27	17
6L 23/09	1588	770	818	32	18
6L 23/11	1611	860	751	60	21
6L 23/13	1761	950	811	65	23
6L 23/16	1926	1085	841	70	26
6L 23/18	2106	1175	931	75	28
6L 23/22	2346	1355	991	83	31
6L 23/26	2606	1535	1071	92	35
6L 23/31	2941	1760	1181	100	39
6L 23/36	3236	1985	1251	108	45

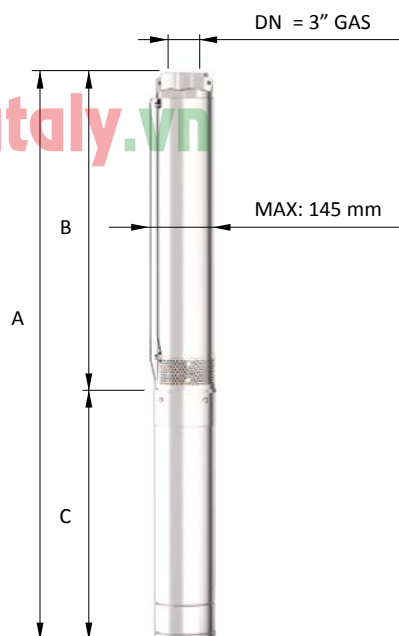

MEI $\geq 0,4$ (direttiva EU No. 547/2012 - regulation EU N. 547/2012)

Tolleranze secondo UNI ISO 9906 livello 3B - Tolerances according to UNI ISO 9906 grade 3B

6" 6L 23

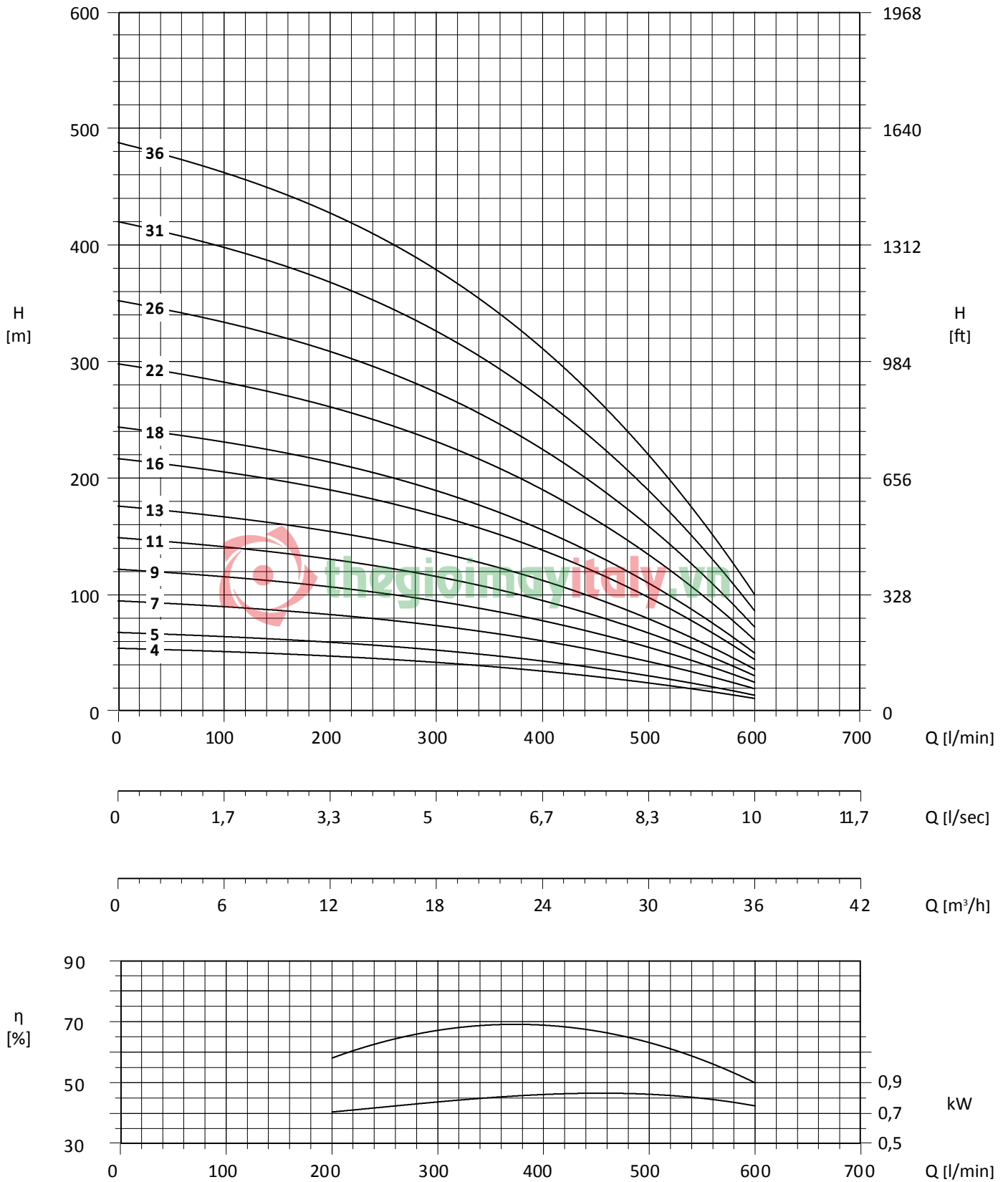

MEI ≥ 0,4 (direttiva EU No. 547/2012 - regulation EU N. 547/2012)
 Tolleranze secondo UNI ISO 9906 livello 3B - Tolerances according to UNI ISO 9906 grade 3B

6" 6L 35

Motor 50 Hz - 2900 rpm				Q							
TYPE	Power		400 V	l/min	0	300	400	500	600	700	800
	(HP)	(kW)	A	l/sec	0	5	6,67	8,33	10	11,67	13,33
				m ³ /h	0	18	24	30	36	42	48
6L 35/04	7,5	5,50	12,5	H[m]	56	53	49	44	37	29	17
6L 35/05	10	7,50	17,5		71	67	62	55	44	36	22
6L 35/06	12,5	9,20	21		85	80	74	66	56	43	26
6L 35/08	15	11	24,5		113	106	98	88	74	57	35
6L 35/09	17,5	13	28		127	120	111	99	84	64	39
6L 35/10	20	15	32		141	133	123	110	93	72	43
6L 35/13	25	18,50	40		183	173	160	143	121	93	56
6L 35/16	30	22	47,5		226	213	197	176	149	115	69
6L 35/19	35	26	55		268	253	234	209	177	136	82
6L 35/21	40	30	62,5		296	279	258	231	195	150	91
6L 35/26	50	37	78		367	346	320	286	242	186	113

Motor 50 Hz 2900 rpm	Dimensions (mm)			Weight (kg)	
	A	B	C	M	P
6L 35/04	1307	609	698	27	16,5
6L 35/05	1371	670	701	55	17
6L 35/06	1482	731	751	60	18
6L 35/08	1664	853	811	75	19
6L 35/09	1755	914	841	70	20
6L 35/10	1938	1007	931	75	21
6L 35/13	2181	1190	991	83	23
6L 35/16	2444	1373	1071	92	26
6L 35/19	2769	1588	1181	100	28
6L 35/21	2961	1710	1251	108	30
6L 35/26	3356	2015	1341	118	33

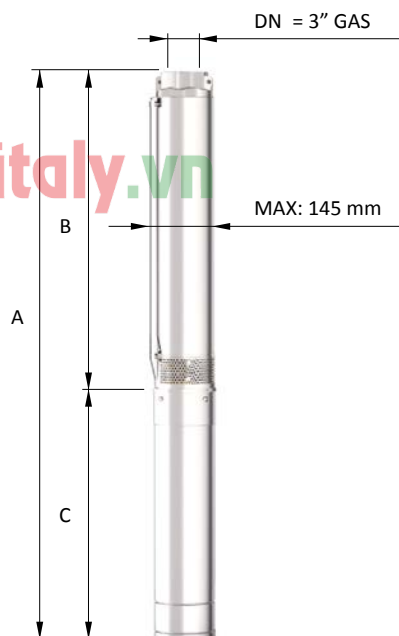

MEI $\geq 0,4$ (direttiva EU No. 547/2012 - regulation EU N. 547/2012)

Tolleranze secondo UNI ISO 9906 livello 3B - Tolerances according to UNI ISO 9906 grade 3B

6" 6L 35

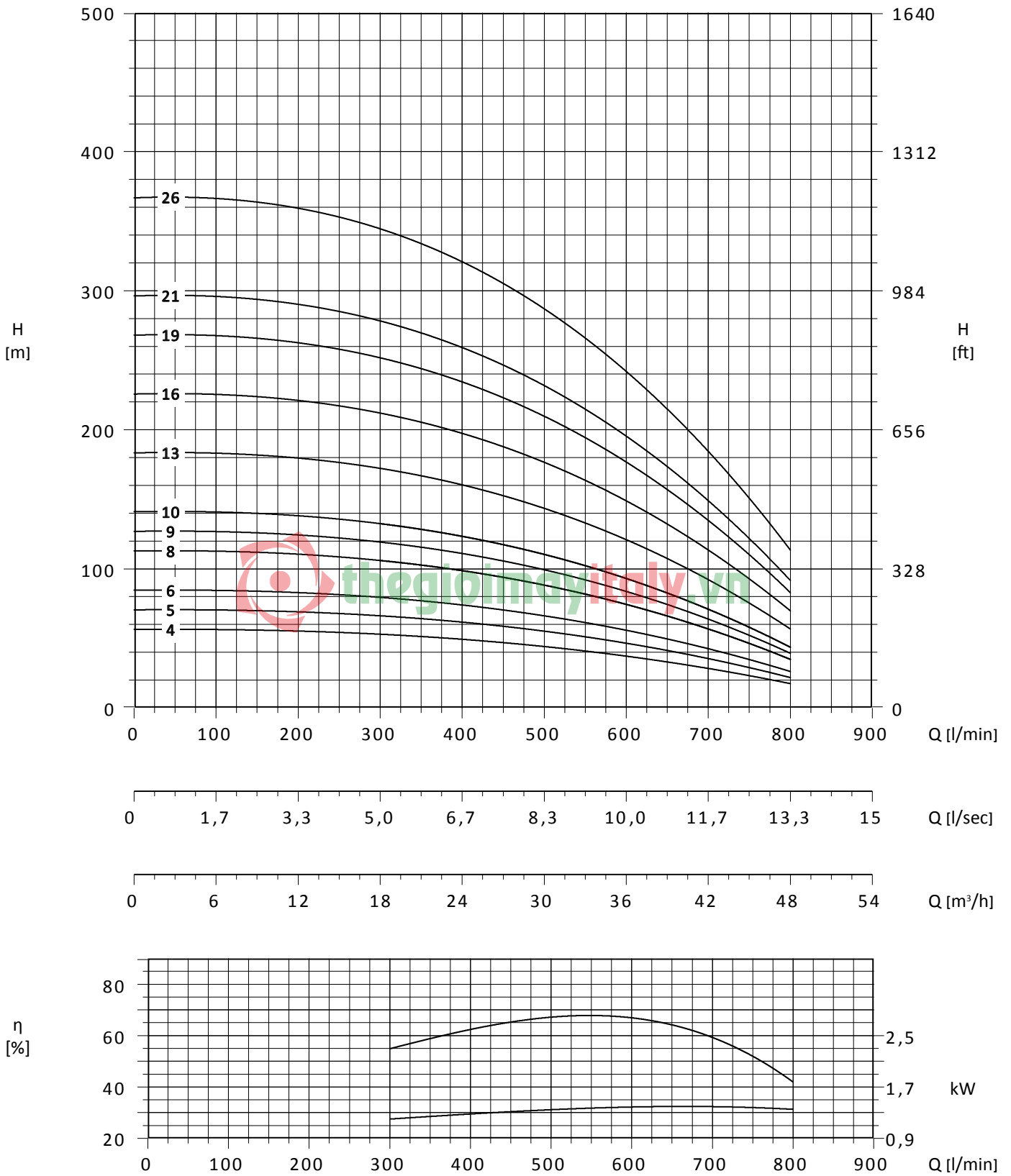

MEI ≥ 0,4 (direttiva EU No. 547/2012 - regulation EU N. 547/2012)
 Tolleranze secondo UNI ISO 9906 livello 3B - Tolerances according to UNI ISO 9906 grade 3B

6" 6L 36

Motor 50 Hz - 2900 rpm				Q						
TYPE	Power		400 V	l/min	0	300	400	500	600	700
	(HP)	(kW)	A	l/sec	0	5	6,67	8	10	11,67
				m ³ /h	0	18	24	30	36	42
6L 36/03	4,0	3	7,5	H[m]	37	30	28	25	22	17
6L 36/04	5,5	4	10		49	40	37	34	29	23
6L 36/06	7,5	5,50	12,5		74	59	56	50	43	35
6L 36/08	10	7,50	17,5		98	79	74	67	58	46
6L 36/10	12,5	9,20	21		123	99	93	84	72	58
6L 36/12	15	11	24,5		147	119	112	101	86	69
6L 36/14	17,5	13	28		172	139	130	118	101	81
6L 36/16	20	15	32		196	158	149	134	115	92
6L 36/20	25	18,50	40		245	198	186	168	144	115
6L 36/23	30	22	47,5		282	228	214	193	166	132
6L 36/28	35	26	55		343	277	260	235	202	161
6L 36/32	40	30	62,5		392	317	298	269	230	184
6L 36/39	50	37	78		478	386	363	328	281	224

Motor 50 Hz 2900 rpm	Dimensions (mm)			Weight (kg)	
TYPE	A	B	C	M	P
6L 36/03	1020	568	452	15	13
6L 36/04	1261	664	597	22	14
6L 36/06	1554	856	698	27	15,5
6L 36/08	1866	1048	818	32	16
6L 36/10	1991	1240	751	60	17,5
6L 36/12	2243	1432	811	65	19
6L 36/14	2465	1624	841	70	21
6L 36/16	2747	1816	931	75	25
6L 36/20	3191	2200	991	83	27
6L 36/23	3559	2488	1071	92	29
6L 36/28	4149	2968	1101	100	32
6L 36/32	4603	3352	1251	108	35
6L 36/39	5365	4024	1341	118	40

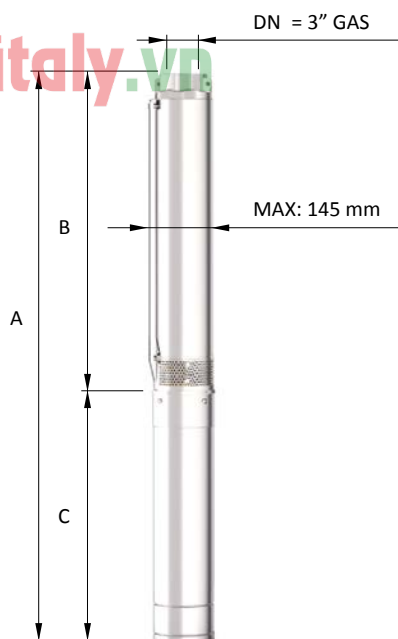

MEI $\geq 0,4$ (direttiva EU No. 547/2012 - regulation EU N. 547/2012)

Tolleranze secondo UNI ISO 9906 livello 3B - Tolerances according to UNI ISO 9906 grade 3B

6" 6L 36

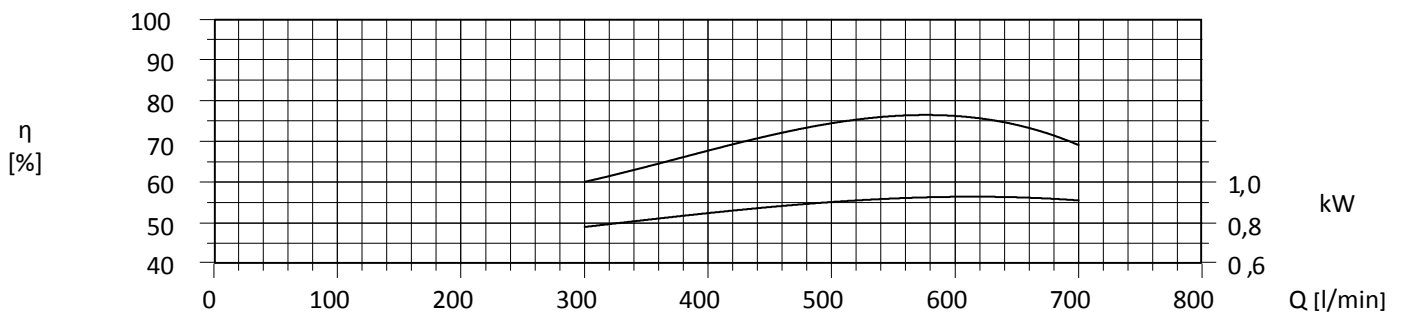
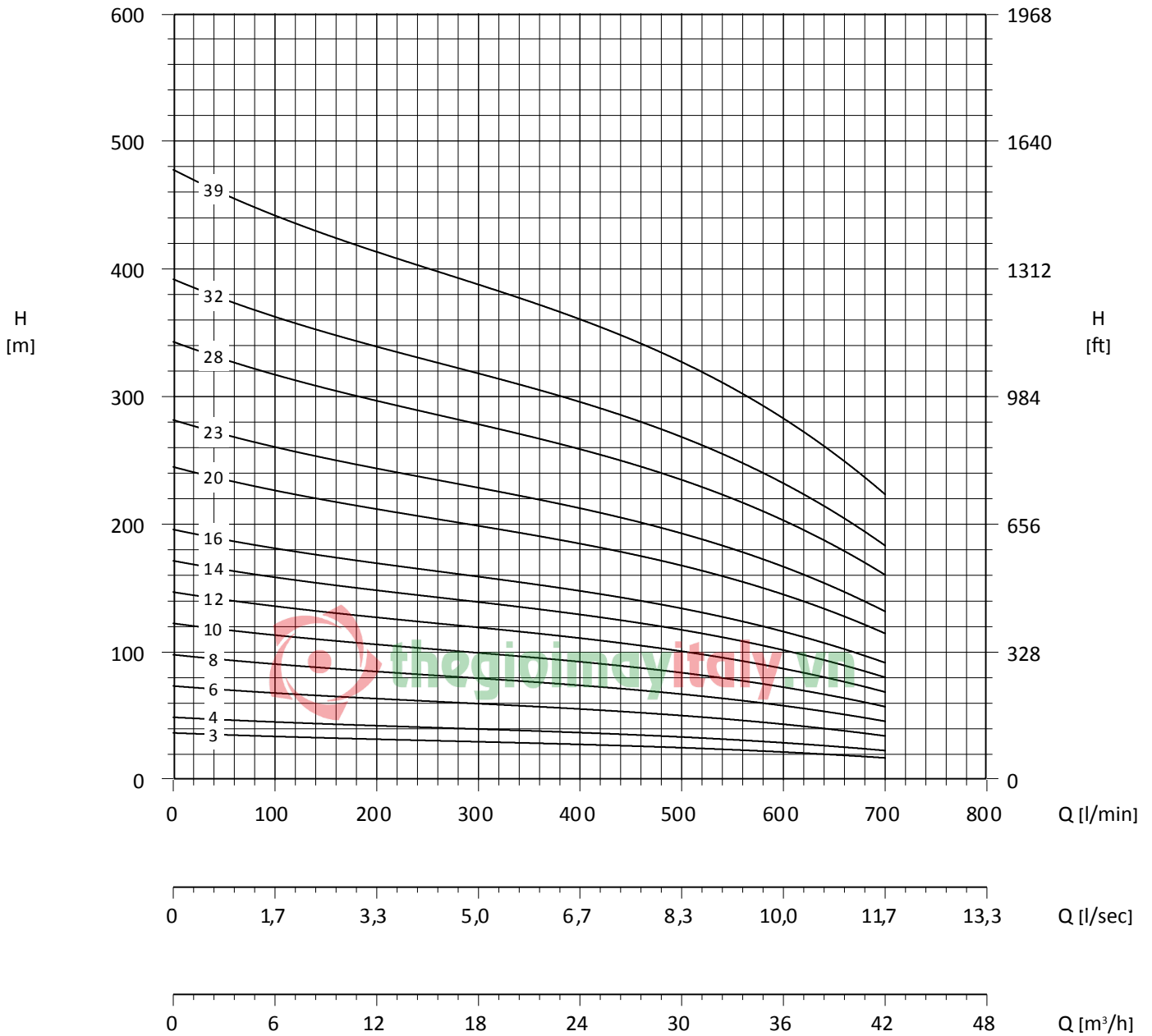

MEI ≥ 0,4 (direttiva EU No. 547/2012 - regulation EU N. 547/2012)
 Tolleranze secondo UNI ISO 9906 livello 3B - Tolerances according to UNI ISO 9906 grade 3B

6" 6L 43

Motor 50 Hz - 2900 rpm				Q							
TYPE	Power		400 V	l/min	0	400	500	600	700	800	900
	(HP)	(kW)	A	l/sec	0	6,67	8,33	10	11,67	13,33	15
				m ³ /h	0	24	30	36	42	48	54,0
6L 43/03	5,5	4	10	H[m]	35	29	27	26	23	19	15
6L 43/04	7,5	5,50	12,5		46	39	37	34	30	25	20
6L 43/06	10	7,50	17,5		69	59	55	51	45	38	30
6L 43/07	12,5	9,20	21		81	68	64	60	53	44	35
6L 43/09	15	11	24,5		104	88	82	77	68	57	45
6L 43/11	17,5	13	28		127	107	101	94	83	70	55
6L 43/12	20	15	32		138	117	110	102	90	76	60
6L 43/15	25	18,50	40		173	146	137	128	113	95	75
6L 43/18	30	22	47,5		207	176	165	153	135	114	90
6L 43/22	35	26	55		253	215	201	187	165	140	110
6L 43/25	40	30	62,5		288	244	229	213	188	159	125
6L 43/31	50	37	78		357	302	284	264	233	197	155

Motor 50 Hz 2900 rpm	Dimensions (mm)			Weight (kg)	
	A	B	C	M	P
6L 43/03	1165	568	597	22	13
6L 43/04	1362	664	698	27	14
6L 43/06	1674	856	818	32	15,5
6L 43/07	1703	952	751	60	16
6L 43/09	1955	1144	811	65	17,5
6L 43/11	2177	1336	841	70	19
6L 43/12	2363	1432	931	75	21
6L 43/15	2711	1720	991	83	25
6L 43/18	3079	2008	1071	92	27
6L 43/22	3573	2392	1181	100	29
6L 43/25	3931	2680	1251	108	32
6L 43/31	4597	3256	1341	118	35

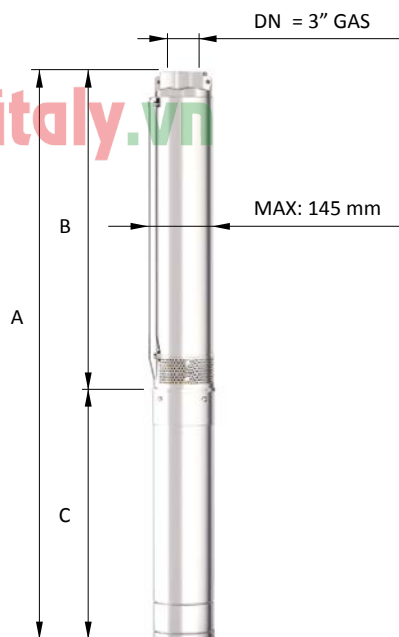

MEI $\geq 0,4$ (direttiva EU No. 547/2012 - regulation EU N. 547/2012)

Tolleranze secondo UNI ISO 9906 livello 3B - Tolerances according to UNI ISO 9906 grade 3B

6" 6L 43

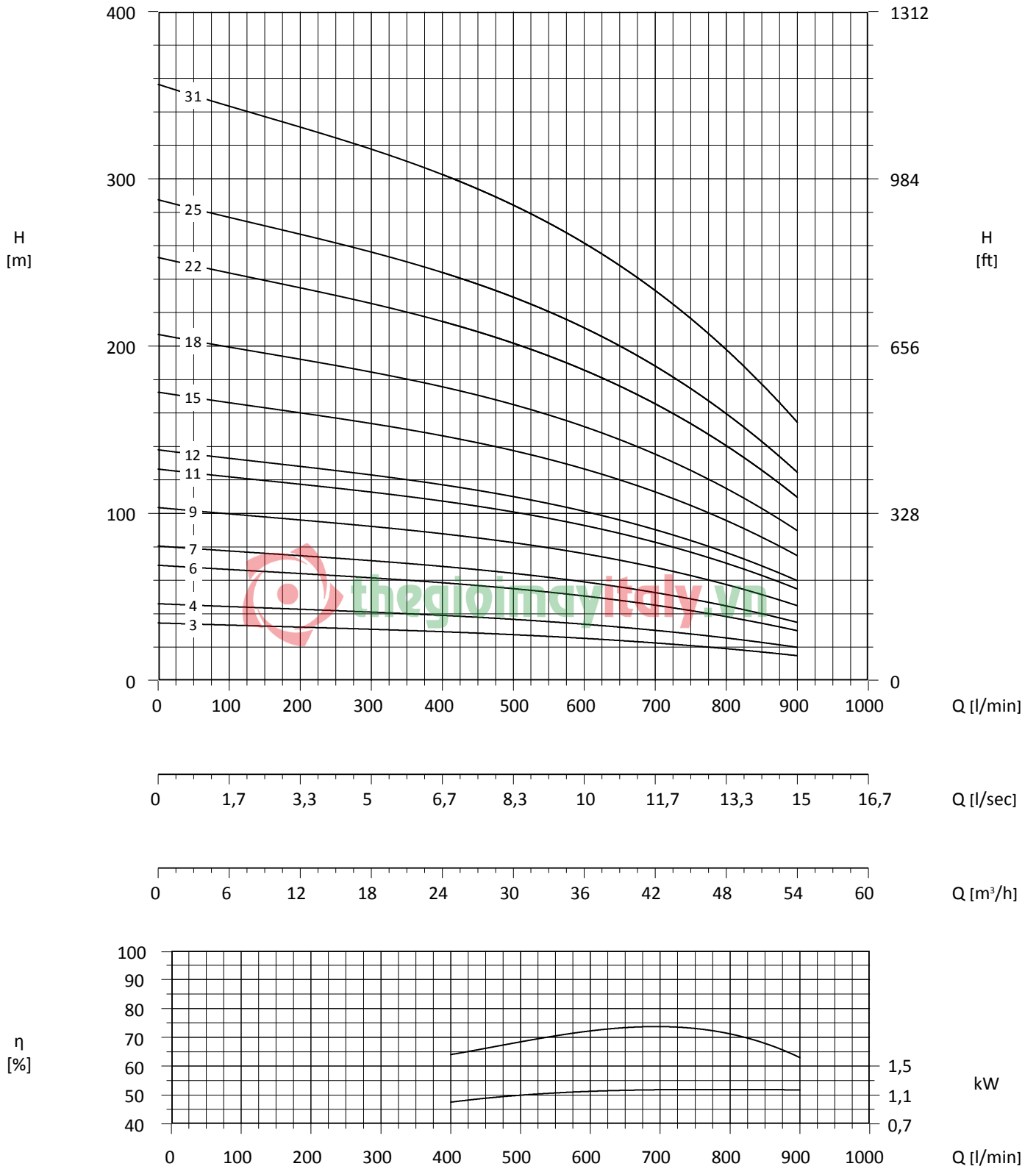

MEI $\geq 0,4$ (direttiva EU No. 547/2012 - regulation EU N. 547/2012)
 Tolleranze secondo UNI ISO 9906 livello 3B - Tolerances according to UNI ISO 9906 grade 3B

6" 6L line

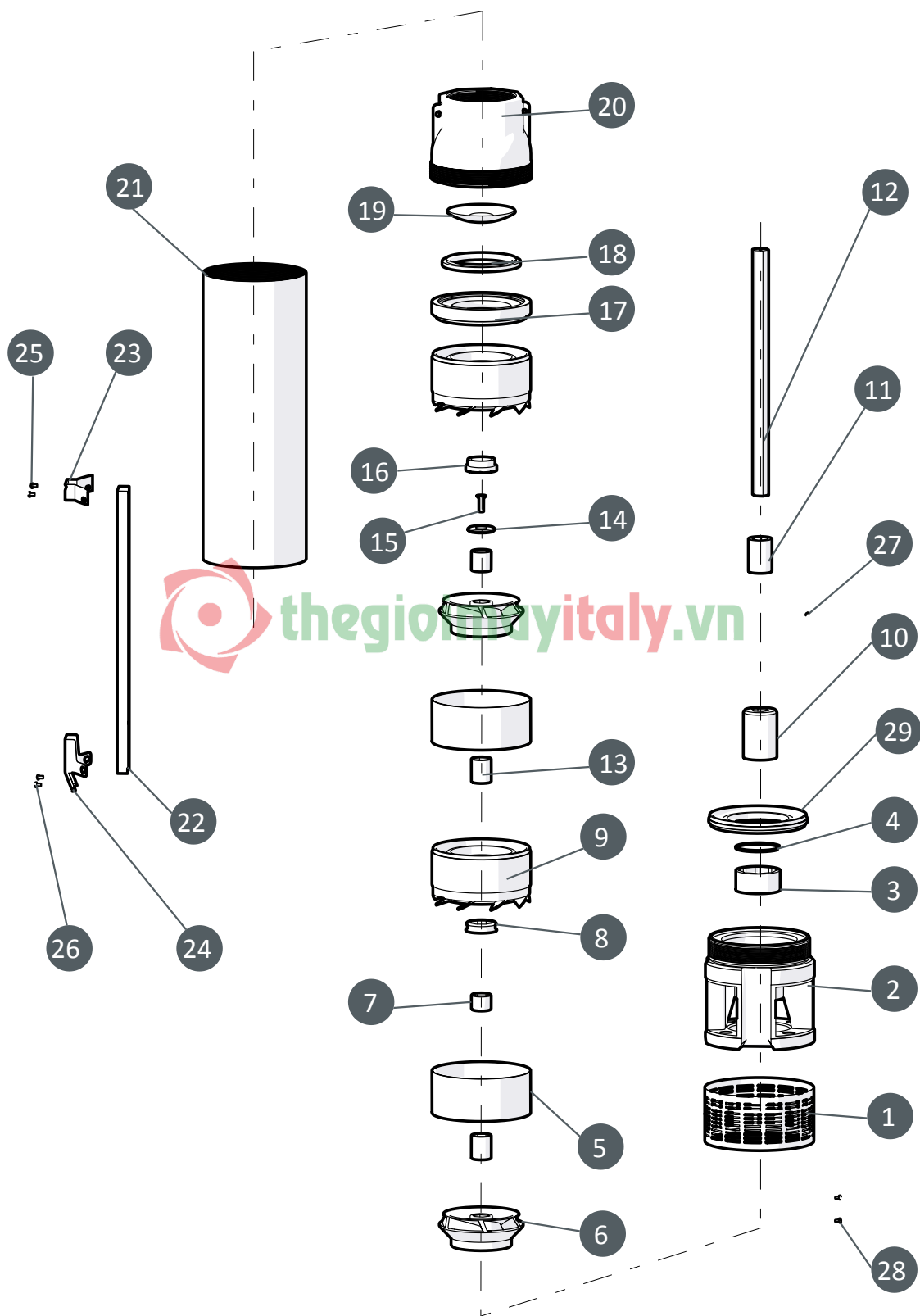

6" 6L line

6L			
N. CODE	DESCRIZIONE (ITALIANO)	DESCRIPTION (ENGLISH)	MATERIAL
1	SUCCHERUOLA	SUCTION STRAINER	AISI 304
2	GABBIA DI ASPIRAZIONE SUCTION CAGE AISI 304	SUCTION CAGE	CAST IRON
3	BRONZINA PER GABBIA	BEARING BUSH FOR SUCTION CAGE RUBBER NBR	RUBBER NBR
4	SEEGER BRONZINA SEEGER	BEARING BUSH	AISI 304
5	ELEMENTO INTERMEDIO	INTERMEDIATE CASING	AISI 304
6	GIRANTE	IMPELLER	NORYL GFN2
7	DISTANZIATORE INTERMEDIO	INTERMEDIATE SPACER	AISI 304
8	BRONZINA DIFFUSORE	DIFFUSER BEARING BUSH	RUBBER NBR
9	DIFFUSORE	DIFFUSER	NORYL GFN2 +RING AISI 304
10	GIUNTO DITRAINO	JOINT	AISI 304
11	DISTANZIATORE PRIMA GIRANTE	SPACER FIRST IMPELLER	NORYL GFN2
12	ALBERO POMPA	PUMP SHAFT	AISI 420
13	DISTANZIATORE	SPACER	NORYL GFN2
14	DISCO ACCIAIO	RING	AISI 304
15	VITE	SCREW	AISI 304
16	CONTROSPENSIONE	COUNTERTHRUST	PTFE+25%CARBON
17	ANELLO GUARNIZIONE MANDATA	RING GASKET VALVE	NORYL GFN2
18	GUARNIZIONE FARFALLA	GASKET VALVE	RUBBER NBR
19	FARFALLA	CAP VALVE	AISI 304
20	MANDATA	DELIVERY BOWL	AISI 304
21	CAMICIA	SLEEVE	AISI 304
22	COPRICAPO	COVER CABLE	AISI 304
23	STAFFETTA SUPERIORE	UPPER FLANGE	AISI 304
24	STAFFETTA INFERIORE	LOWER FLANGE	AISI 304
25	N.2 VITI M4 X 10 PER STAFFETTA SUPERIORE	N.2 SCREW M4X10 FOR UPPER FLANGE	AISI 304
26	N.2 VITI M4 X 10 PER STAFFETTA INFERIORE	N.2 SCREW M4X10 FOR LOWER FLANGE	AISI 304
27	GRANO PER GIUNTO	SCREW	AISI 304
28	N.2 VITI M4 X 8 PER SUCCHERUOLA	N.2 SCREW M4X8 SUCTION STRAINER	AISI 304
29	ANELLO RACCORDO GABBIA	RING FOR SUCTION CAGE	NORYL GFN2 + RING AISI 304



N. CODE	DESCRIPTION (FRANCAIS)	DESCRIPTION (ESPAÑOL)	MATERIAL
1	CREPINE	REJILLA	AISI 304
2	CAGE D'ASPIRATION	CUERPO DE ASPIRACION	AISI 304
3	BEARING BUSH POUR CAGE D'ASPIRATION	COJINETE CUERPO DE ASPIRACION	RUBBER NBR
4	SEEGER BEARING BUSH	SEEGER POR COJINETE	AISI 304
5	ELEMENT INTERMEDIARE	ELEMENTO INTERMEDIO	AISI 304
6	ROUE	IMPULSOR	NORYL GFN2
7	ENTRETOISE INTERMEDIARE	DISTANCIADOR INTERMEDIO	AISI 304
8	DIFFUSEUR BEARING BUSH	COJINETE DIFUSOR	RUBBER NBR
9	DIFFUSEUR	DIFUSOR	NORYL GFN2 +RING AISI 304
10	JOINT	ACOPLAMIENTO	AISI 304
11	ENTRETOISE PREMIERE ROUE	DISTANCIADOR PRIMER IMPULSOR	NORYL GFN2
12	ARBRE POMPE	EJE DE BOMBA	AISI 420
13	ENTRETOISE	DISTANCIADOR	NORYL GFN2
14	RING	ANILLO EN ACERO	AISI 304
15	VIS	TORNILLO	AISI 304
16	CONTRESUSPENSION	CONTRA-SUSPENSION	PTFE+25%CARBON
17	ANNEAU VALVE GASKET	JUNTA PARA VALVULA	NORYL GFN2
18	BAGUE VALVE GASKET	JUNTA VALVULA	RUBBER NBR
19	PLAT	VALVULA	AISI 304
20	REFOULEMENT	CUERPO DE IMPULSION	AISI 304
21	CHEMISE	CAMISA	AISI 304
22	PROTECTION CABLE	PARACABLE	AISI 304
23	BRIDE SUPERIEURE	GRAPA SUPERIOR	AISI 304
24	BRIDE INFERIEURE	GRAPA INFERIOR	AISI 304
25	N.2 VIS M4X10 POUR BRIDE SUPERIEURE	N.2 TORNILLOS GRAPA SUPERIOR	AISI 304
26	N.2 VIS M4X10 POUR BRIDE INFERIEURE	N.2 TORNILLOS GRAPA INFERIOR	AISI 304
27	VIS	TORNILLO POR ACOPLAMIENTO	AISI 304
28	N.2 VIS M4X8 POUR CREPINE	N.2 TORNILLOS REJILLA	AISI 304
29	ANNEAU FOR CAGE D'ASPIRATION	ANILLO CUERPO DE ASPIRACION	NORYL GFN2 + RING AISI 304