

KC

monogirante



 thegioimayitaly.vn



NOMENCLATURA PARTI DI RICAMBIO
SPARE PARTS LIST
NOMENCLATURE PIECES DE RECHANGE
NOMENCLATURA REPUESTOS

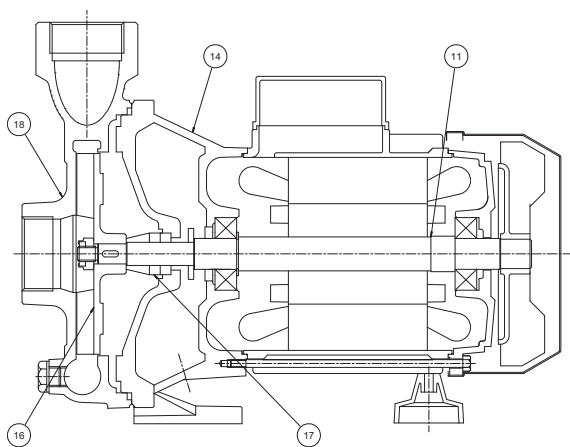

- 11 Albero con rotore – Pump shaft + rotor
Arbre + rotor – Eje rotor
- 14 Supporto mandata – Outlet bracket
Support envoyée – Soporte entrega
- 16 Girante – Impeller
Turbine – Impulsor
- 17 Tenuta meccanica – Mechanical seal
Garniture mécanique – Cierre mecánico
- 18 Corpo pompa – Pump body
Corp de pompe – Cuerpo bomba

ELETTROPOMPE CENTRIFUGHE MONOGIRANTE 1"1/2

Le elettropompe centrifughe monogiranti della serie KC sono state progettate per pompare liquidi puliti senza parti abrasive, senza corpi solidi in sospensione, non esplosivi o aggressivi per i materiali della pompa

- Temperatura max. del liquido fino a 35 °C per uso domestico (CEI EN 60335-2-41) o 90 °C per altri usi e temperatura ambiente fino a 40 °C.
- Portate fino a 21 m³/h.
- Prevalenze fino a ~ 35 m.

CARATTERISTICHE COSTRUTTIVE

- Corpo pompa: ghisa G20 con trattamento anticorrosione
- Supporto motore: ghisa G20 con trattamento anticorrosione
- Girante: ottone stampato UNI-EN 12165
- Albero pompa: acciaio inox Aisi 304
- Tenuta meccanica: carbone-ceramica

MOTORE

I motori di comando sono del tipo asincrono a gabbia di scoiattolo chiusi, a ventilazione esterna

- Motoprotettore incorporato e condensatore permanentemente inserito per i tipi monofasi
- La protezione del motore nella versione trifase è a cura del cliente e si raccomandano apparecchiature in accordo con le norme vigenti
- Isolamento classe F – servizio S1- grado di protezione IP 44
- Protezione morsettiera IP 54

CENTRIFUGAL ELECTRIC PUMPS ONE IMPELLER 1"1/2

The close-coupled centrifugal electric pumps with one impeller series KC have been designed to pump clear liquids, without abrasives and suspended solids, non-explosive or aggressive for the pump's materials

- Liquid temperature not higher than 35 °C for domestic use (CEI EN 60335-2-41) or 90 °C for other use, while the ambient temperature must not be higher than 40 °C
- Flow rate up to ~ 21 m³/h
- Heads up to ~ 35 m

TECHNICAL FEATURES

- Pump body: cast iron G20 with anti-corrosive coating
- Motor bracket: cast iron G20 with anti-corrosive coating
- Impeller: stamped brass UNI-EN 12165
- Pump shaft: stainless steel Aisi 304
- Mechanical seal: carbon-ceramics

MOTOR

The control motors are asynchronous, squirrel cage-type, closed, with external ventilation

- Incorporated motor protection and capacitor always on, for single-phase models
- The motor protection for three-phase models must be installed by the customer. Equipment compliant with current standards should be used
- Class of insulation: F-service: S1- Degree of protection: IP 44
- Terminal board protection: IP 54



ÉLECTROPOMPES CENTRIFUGES À UNE ROUE 1"1/2

Les électropompes centrifuges à une roue de la série KC ont été conçues pour pomper des liquides propres sans parties abrasives, sans corps liquides en suspension, non explosifs ou agressifs pour les matériaux de la pompe

- Température max. du liquide jusqu'à 35 °C pour utilisation domestique (CEI EN 60335-2-41) ou 90 °C pour d'autres utilisations et température ambiante jusqu'à 40 °C.
- Plage d'utilisation jusqu'à 21 m³/h.
- Hauteur manométrique jusqu'à ~ 35 m.

CARACTERISTIQUES DE CONSTRUCTION

- Corps de pompe : En fonte G20 avec traitement anti-corrosion
- Lanterne: En fonte G20 avec traitement anti-corrosion
- Turbine: laiton étampé UNI-EN 12165
- Abre de pompe: acier inox Aisi 304
- Garniture mécanique: Carbone dur - Céramique

MOTOR

Le moteurs sont asynchrones à cage d'écureuil fermés à ventilation extérieure monofásicos,

- Pour le modèles monophasé son avec protection thermique et condensateur connecté en permanence
- Pour les modèles triphasés, la protection est à la charge de l'utilisateur. A recommandé l'équipement conformément à la réglementation
- A Classe d'isolation F - service S 1 – protection IP44
- Protection IP54 dans le terminal

ELECTROBOMBAS CENTRÍFUGAS MONOIMPULSOR 1"1/2

Las electrobombas centrifugas con monoimpulsor de la serie KC han sido proyectadas para bombear líquidos limpios sin partes abrasivas, sin cuerpos sólidos en suspensión, que no sean explosivos ni agresivos para los materiales de la bomba.

- Temperatura max. del líquido hasta 35 °C para uso doméstico (CEI EN 60335-2-41) o 90 °C para otros usos y temperatura ambiente hasta 40 °C.
- Caudal hasta 21 m³/h.
- Alturas hasta ~ 35 m.

CARACTERÍSTICAS DE CONSTRUCCIÓN

- Cuerpo de bomba: Fundición gris G20 con tratamiento contra-corrosión
- Soporte: Fundición gris G20 con tratamiento contra-corrosión
- Rodete: De latón UNI-EN 12165
- Eje de la bomba: de acero Inox AISI304
- Cierre mecánico: De cerámica y grafito

MOTOR

Los motores de accionamiento son asíncrono de jaula de ardilla cerrados, ventilados externamente

- Para los modelos monofásicos, protección térmica y condensador incorporado
- Para los modelos trifásicos de la protección se encarga el usuario y el equipo recomendado de acuerdo con las normas
- Aislamiento de Clase F – funcionamiento S1- proteccion IP44
- Proteccion IP54 para el terminal

50 Hz - min⁻¹ ~ 2900

TIPO TYPE		Potenza nominale Nominal power		Potenza assorbita Input power [W]		Condensatore Capacitor 450 V max	Corrente assorbita Input current [A]			Portata - Capacity									
Monofase Single-phase	Trifase Three-phase	kW	HP	a	b	[µF]				Q [m ³ /h]	0	3	6	9	12	15	18	21	
										Q [l/1']	0	50	100	150	200	250	300	350	
											Prevalenza (m C.A.) Total head (m W.C.)								
a	b						1-230V	3-230V	3-400V	H [m]	24.5	24.3	23.7	22.8	21.5	19.8	17.7	15.2	
KC 150 M	KC 150 T	1.1	1.5	1920	1850	31,5	8.5	6.4	3.7		30.1	29.4	28.6	27.4	26.1	24.5	22.7	20.7	
KC 200 M	KC 200 T	1.47	2	2670	2450	45	11.7	8.3	4.8		35.5	34.4	33.0	31.4	29.6	27.5	25.3	22.8	
	KC 300 T	2.2	3	-	3030	-	-	8.9	5.1										

a) - Monofase 230 V

b) - Trifase 230/400 V

60 Hz - min⁻¹ ~ 3400

TIPO TYPE		Potenza nominale Nominal power		Potenza assorbita Input power [W]		Condensatore Capacitor 450 V max	Corrente assorbita Input current [A]			Portata - Capacity									
Monofase Single-phase	Trifase Three-phase	kW	HP	a	b	[µF]				Q [m ³ /h]	0	3	6	9	12	15	18	21	
										Q [l/1']	0	50	100	150	200	250	300	350	
											Prevalenza (m C.A.) Total head (m W.C.)								
a	b						1-220V	3-220V	3-380V	H [m]	23,3	23,2	23,0	22,5	21,6	20	18,3	16,2	
KC 150 M	KC 150 T	1,1	1,5	2065	1250	36	9,6	5,9	3,3		30,3	30,0	29,9	29,5	28,4	27,3	25,6	23,7	
KC 200 M	KC 200 T	1,47	2	2870	1710	45	13	7,6	4,5		34,6	34,3	34,0	33,4	32,1	30,7	29,0	26,9	
	KC 300 T	2,2	3	-	3250	-	-	9,1	5,5										

a) - Monofase 220 V

b) - Trifase 220/380 V

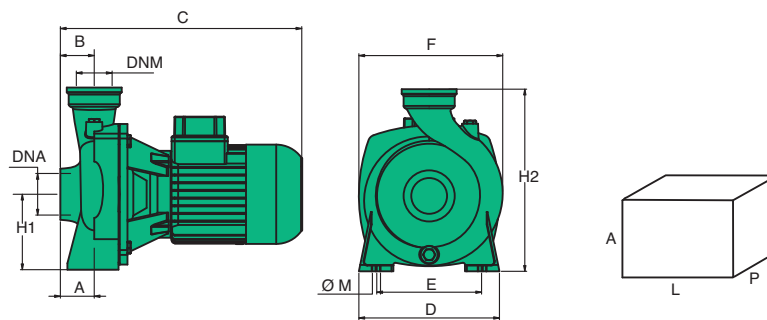

TIPO TYPE	DIMENSIONI [mm] DIMENSIONS [mm]											IMBALLO [mm] PACKING [mm]			PESO WEIGHT [kg]
	A	B	C	D	E	F	Ø M	H1	H2	DNA	DNM	A	L	P	
KC 150	33	54	370	223	160	230	11	118	292	1"1/2	1"1/2	350	430	240	24.5
KC 200	33	54	382	223	160	230	11	118	292	1"1/2	1"1/2	350	430	240	25.4
KC 300	33	54	382	223	160	230	11	118	292	1"1/2	1"1/2	350	440	260	27

$\text{min}^{-1} \sim 2900$

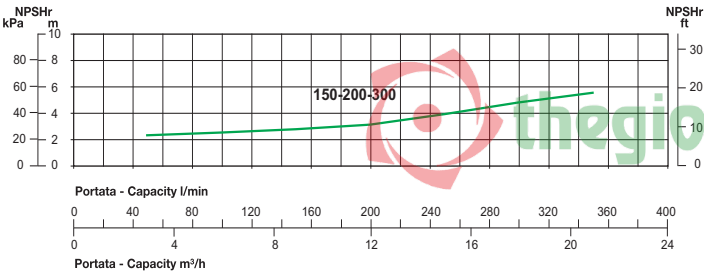
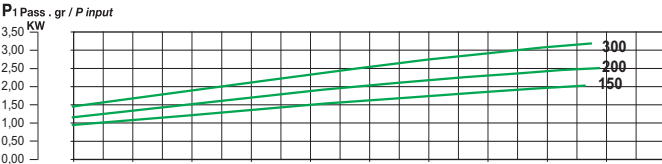
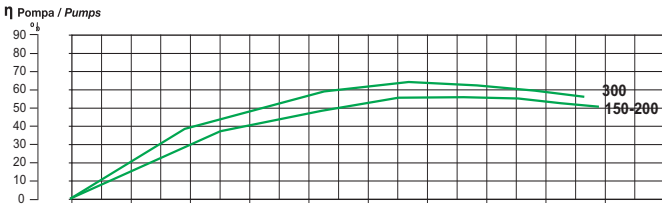
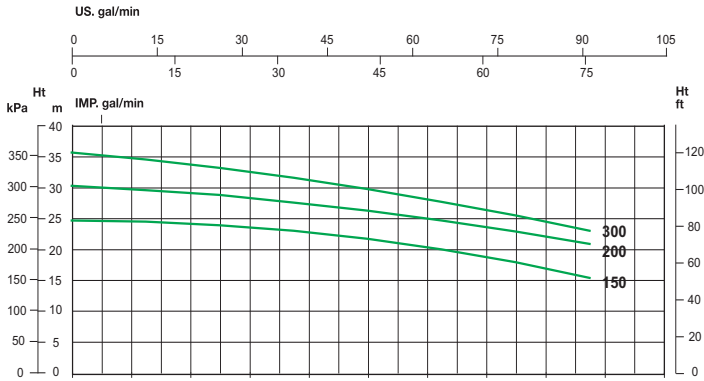

$\text{min}^{-1} \sim 3400$

