

SKUBA

sommergibili per drenaggio



NOMENCLATURA PARTI DI RICAMBIO

SPARE PARTS LIST

NOMENCLATURE PIECES DE RECHANGE

NOMENCLATURA REPUESTOS

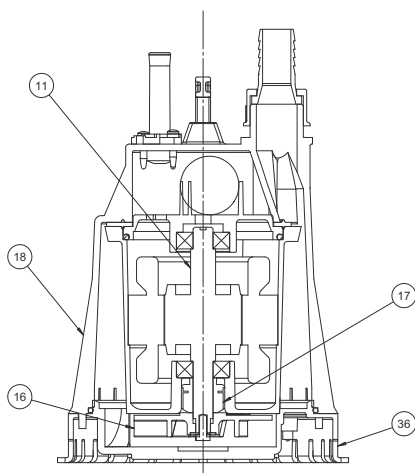

- 11 Albero con rotore – Pump shaft + rotor
Arbre + rotor – Eje rotor
- 16 Girante – Impeller
Turbine – Impulsor
- 17 Tenuta meccanica – Mechanical seal
Garniture mécanique – Cierre mecánico
- 18 Corpo pompa – Pump body
Corp de pompe – Cuerpo bomba
- 36 Base filtro – Filter base
Base filtre – Filtro básico

ELETTROPOMPE SOMMERGIBILI PER DRENAGGIO

Elettropompe sommergibili a girante aperta della serie SKUBA sono state progettate per pompare liquidi puliti o parzialmente sporchi, senza parti abrasive o corpi solidi in sospensione, non esplosivi o aggressivi per i materiali della pompa.
Temperatura max. del liquido fino a 35 °C. (CEI EN 60335-2-41). Le pompe possono lavorare anche parzialmente sommerse.

CARATTERISTICHE COSTRUTTIVE

- Corpo pompa, girante, testata, manico di trasporto e base filtro: Technopolimero
- Corpo motore: in alluminio pressofuso UNI 5076
- Albero pompa e viti: in acciaio inox Aisi 420 F
- Tenuta meccanica in carbone-ceramica
- 5 m cavo alimentazione tipo H05RN-F
- Immersione max. 5 m

MOTORE

- Motore ad induzione a due poli, riavvolgibile, refrigerato dal liquido pompato, con protezione IP68, isolamento classe F.
- Alimentazione monofase con motoprotettore incorporato e condensatore permanentemente inserito.
- Servizio continuo se completamente sommersa.

A RICHIESTA:

- Versione automatica con galleggiante flottante (SKUBA Aut).

SUBMERSIBLE DRAINING ELECTRIC PUMPS

The submersible electric pumps with open impeller series SKUBA have been designed to pump clear or slightly dirty liquids, without abrasives and suspended solids, non-explosive or aggressive for the pump's materials.
Liquid temperature not higher than 35 °C (CEI EN 60335-2-41). The pumps may work also partially immersed.

TECHNICAL FEATURES

- Pump body, impeller, outer motor casing, filter base and handle: Technopolymer
- Motor body: in die casting aluminium UNI 5076
- Pump shaft and screws: in stainless steel Aisi 420 F
- Mechanical seal in carbon-ceramics
- 5 m H05RN-F feeding cable
- Max. immersion 5 m

MOTOR

- Two poles induction rewindable motor, cooled by the pumped liquid, with protection IP 68, class F insulation.
- Single-phase feeding with incorporated motor protector and capacitor permanently connected.
- Continuous duty if completely submerged.

ON REQUEST:

- Automatic version with float switch (SKUBA Aut).



ÉLECTROPOMPES SUBMERSIBLES POUR DRAINAGE

Les électropompes submersibles à roue ouverte de la série SKUBA ont été conçues pour pomper des liquides propres ou partiellement sales, sans parties abrasives ou corps solides en suspension, non explosifs ou agressifs pour les matériaux de la pompe.
Température max. du liquide jusqu'à 35 °C. (CEI EN 60335-2-41). Les pompes peuvent fonctionner même partiellement immergées.

CARACTERISTIQUES DE CONSTRUCTION

- Corps de pompe, Turbine, couvercle avec la poignée et filtre: Technopolimère
- Corps de moteur: aluminium moulé sur pression UNI 5076
- Abre de pompe et vis en acier inox Aisi 420 F
- Garniture mécanique en Carbone dur - Céramique
- 5 m Câble d'alimentation H07RN-F.
- Immergée max. 5 mt

MOTOR

- Moteur à induction à deux pôles rebobinable, refroidi par le liquide pompé, protection IP68, classe d'isolation F.
- Le modèles monophasé son avec protection thermique et condensateur connecté en permanence
- Service S1

SUR DEMANDE:

- Version avec flotteur automatique (SKUBA Aut.)

ELECTROBOMBAS SUMERGIBLES DE DRENAJE

Electrobombas sumergibles a impulsor con impulsor abierto de la serie SKUBA han sido proyectadas para bombear líquidos limpios o parcialmente sucios, sin partes abrasivas o cuerpos sólidos en suspensión, que no sean explosivos ni agresivos para los materiales de la bomba.
Temperatura max. del líquido hasta 35 °C. (CEI EN 60335-2-41). Las bombas pueden funcionar incluso sumergidas parcialmente.

CARACTERISTICAS DE CONSTRUCCIÓN

- Cuerpo de bomba, Rodete, filtro y tapa con el mango: De tecnopolímero
- Cuerpo de motor: fundición de aluminio UNI 5076
- Eje de la bomba y tornillo: de acero Inox Aisi 420 F
- Cierre mecánico: De cerámica y grafito
- Cable de alimentación: 5 mt H07RN-F
- Máxima inmersión: 5 mt

MOTOR

- Motor a induction de dos poles rebobinables, enfriado por el líquido bombeado, protección IP68, aislamiento de clase F.
- Para los modelos monofásicos, protección térmica y condensador incorporado
- Funcionamiento S1

BAJO DEMANDA:

- Versión con interruptor de nivel automático (SKUBA Aut)

50 Hz

TIPO TYPE Monofase Single-phase	Potenza nominale Nominal power		Potenza assorbita Input power [W]	Conden- satore Capacitor 450 V max [µF]	Corrente assorbita Input current [A]	Portata - Capacity										
						Q [m ³ /h]	0	0.6	1.2	1.8	2.4	3	3.6	4.2	4.8	5.4
						Q [l/1']	0	10	20	30	40	50	60	70	80	90
						Prevalenza (m C.A.) Total head (m W.C.)										
	kW	HP			1- 230 V	H [m]	6.0	5.3	4.7	4.1	3.6	3.1	2.6	2.2	1.8	1.5
SKUBA 35 EVO	0.26	0.35	240	6.3	1	H [m]	6.0	5.3	4.7	4.1	3.6	3.1	2.6	2.2	1.8	1.5

a) - Monofase 230 V

60 Hz

TIPO TYPE Monofase Single-phase	Potenza nominale Nominal power		Potenza assorbita Input power [W]	Conden- satore Capacitor 450 V max [µF]	Corrente assorbita Input current [A]	Portata - Capacity										
						Q [m ³ /h]	0	0.6	1.2	1.8	2.4	3	3.6	4.2	4.8	5.4
						Q [l/1']	0	10	20	30	40	50	60	70	80	90
						Prevalenza (m C.A.) Total head (m W.C.)										
	kW	HP			1- 220 V	H [m]	9,5	8,6	7,5	6,4	5,2	4	2,6	1,2		
SKUBA 35 EVO	0,26	0,35	320	4	1,52	H [m]	9,5	8,6	7,5	6,4	5,2	4	2,6	1,2		

a) - Monofase 220 V

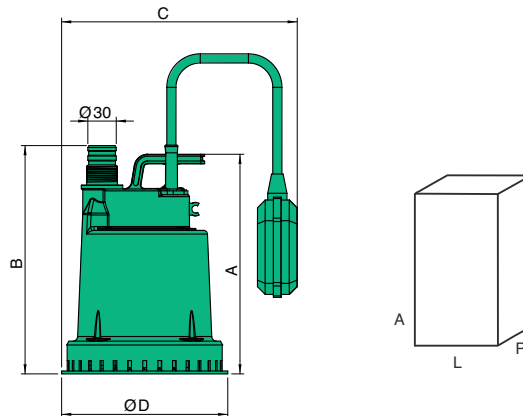

TIPO TYPE	DIMENSIONI [mm] DIMENSIONS [mm]					IMBALLO [mm] PACKING [mm]			PESO WEIGHT [kg]
	A	B	C	D	DNM	A	L	P	
SKUBA 35	240	220	275	163	1"	300	250	180	3,8

$\text{min}^{-1} \sim 2900$

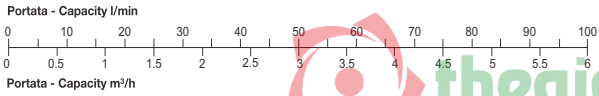
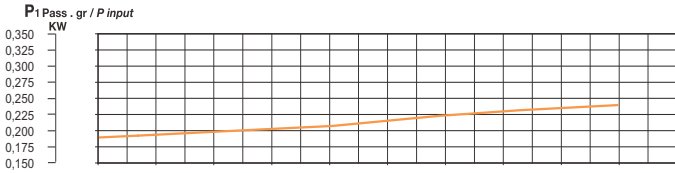
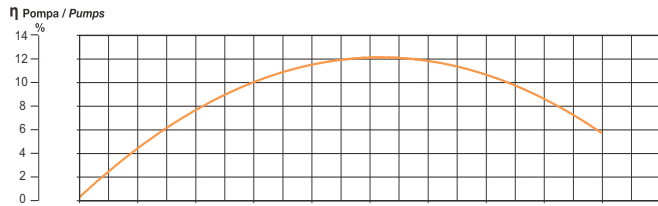
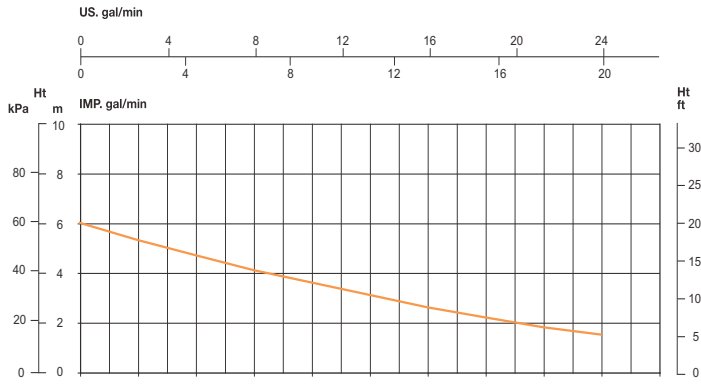

$\text{min}^{-1} \sim 3400$

